

# **Township of Somerset Zoning Ordinance**

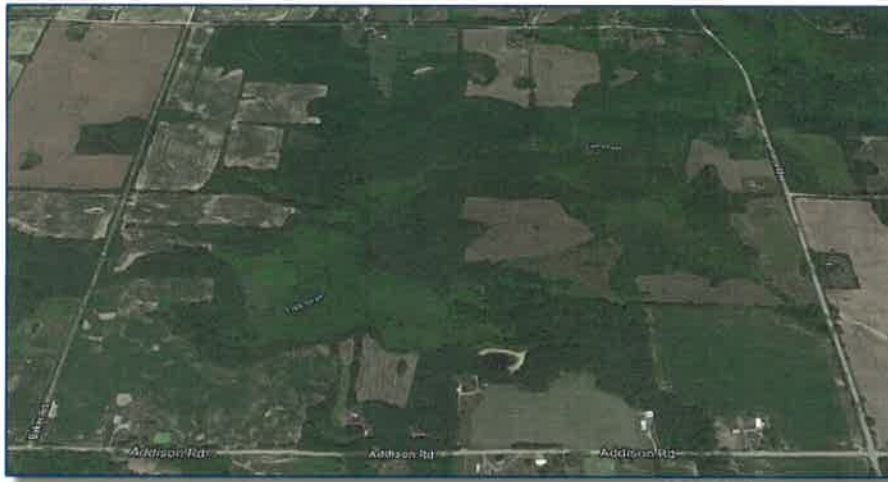

*This page is intentionally blank.*

## TABLE OF CONTENTS

	Page
<b>Article I - <u>IN GENERAL</u></b> .....	1
Section 1.1 - <u>Enacting Clause</u> .....	1
Section 1.2 - <u>Title</u> .....	1
Section 1.3 - <u>Purposes</u> .....	1
Section 1.4 - <u>Scope</u> .....	2
Section 1.5 - <u>Application of Regulations</u> .....	2
<b>Article II - <u>ZONING DISTRICTS</u></b> .....	3
Section 2.1 - <u>Establishment of Zoning Districts</u> .....	3
Section 2.2 - <u>Township of Somerset Official Zoning Map</u> .....	3
Section 2.3 - <u>Interpretation of Zoning District Boundaries</u> .....	3
Section 2.4 - <u>Zoning Districts Regulations</u> .....	3
2.4.1 - <u>Agricultural Zoning Districts</u> .....	3
a - <u>Agricultural District (AG-1)</u> .....	4
2.4.2 - <u>Residential Zoning Districts</u> .....	4
a - <u>Rural Non-Farm Residential District (RNF-1)</u> .....	4
b - <u>Suburban Residential District (RS-1)</u> .....	4
c - <u>Lake Residential District (RL-1)</u> .....	4
d - <u>Multiple-Family Residential District (RM-1)</u> .....	5
2.4.3 - <u>Commercial Zoning Districts</u> .....	5
a - <u>General Commercial District (C-1)</u> .....	5
b - <u>Highway Service Commercial District (C-2)</u> .....	5
2.4.4 - <u>Industrial Zoning Districts</u> .....	5
a - <u>Light Industrial District (I-I)</u> .....	6
Section 2.5 - <u>Tables of Permitted and Conditional Uses</u> .....	6
2.5.1 - <u>Agricultural Uses</u> .....	6
2.5.2 - <u>Residential Uses</u> .....	6

	Page
2.5.3 - <a href="#">Commercial Uses</a> .....	7
2.5.4 - <a href="#">Light Industrial Uses</a> .....	8
2.5.5 - <a href="#">Educational, Childcare, Health Care, and Animal Care Uses</a> .....	9
2.5.6 - <a href="#">Recreational Uses</a> .....	10
2.5.7 - <a href="#">Institutional and Infrastructure Uses</a> .....	11
Section 2.6 - <a href="#">Zoning District Area, Yard, Height, and Bulk Regulations</a> .....	12
<b>ARTICLE III - <a href="#">SUPPLEMENTAL REGULATIONS</a></b> .....	<b>17</b>
Section 3.1 - <a href="#">Purpose</a> .....	17
Section 3.2 - <a href="#">Reserved</a> .....	17
Section 3.3 - <a href="#">Access to Public Roads</a> .....	17
Section 3.4 - <a href="#">Curb Cuts and Driveways</a> .....	17
Section 3.5 - <a href="#">Visibility at Intersections</a> .....	17
Section 3.6 - <a href="#">Off-Road Parking Regulations</a> .....	17
Section 3.7 - <a href="#">Off-Road Loading and Unloading Regulations</a> .....	20
Section 3.8 - <a href="#">Essential Services</a> .....	21
Section 3.9 - <a href="#">Flood Plains</a> .....	21
Section 3.10 - <a href="#">Performance Standards</a> .....	21
Section 3.11 - <a href="#">Home Occupations</a> .....	22
Section 3.12 - <a href="#">Medical Marijuana</a> .....	22
3.12.1 - <a href="#">Medical Marijuana Caregiver Grow Operations</a> .....	22
3.12.2 - <a href="#">Medical Marijuana Home Uses</a> .....	25
Section 3.13 - <a href="#">Storage of Materials</a> .....	26
Section 3.14 - <a href="#">Mobile Homes and Travel Trailers</a> .....	26
Section 3.15 - <a href="#">Fences</a> .....	27
Section 3.16 - <a href="#">Temporary or Seasonal Uses</a> .....	27
Section 3.17 - <a href="#">Communication Towers</a> .....	27
Section 3.18 - <a href="#">Outdoor Wood Furnaces</a> .....	30
<b>ARTICLE IV - <a href="#">ADMINISTRATION AND AMENDMENT OF THE ZONING ORDINANCE</a></b> .....	<b>33</b>
Section 4.1 - <a href="#">Administration of the Zoning Ordinance</a> .....	33
Section 4.2 - <a href="#">Zoning Compliance Permits</a> .....	33
Section 4.3 - <a href="#">Certificate of Occupancy, Final Inspection</a> .....	34

	Page
Section 4.4 – <a href="#">Fees and Charges</a> .....	34
Section 4.5 - <a href="#">Enforcement</a> .....	35
Section 4.6 - <a href="#">Public Hearing Notice Regulations</a> .....	36
Section 4.7 - <a href="#">Nonconformities</a> .....	36
Section 4.8 - <a href="#">Site Plan Review and Approval</a> .....	39
Section 4.9 - <a href="#">Conditional Uses</a> .....	41
Section 4.10 - <a href="#">Additional Development Regulations for Certain Conditional Uses</a> .....	43
4.10.1 - <a href="#">Bed and Breakfast Facilities</a> .....	43
4.10.2 - <a href="#">Drive-In Theaters</a> .....	44
4.10.3 - <a href="#">Funneling</a> .....	44
4.10.4 - <a href="#">Junk Yards</a> .....	45
4.10.5 - <a href="#">Mobile Home Parks</a> .....	46
4.10.6 - <a href="#">Mobile Home Subdivisions</a> .....	46
4.10.7 - <a href="#">ORV Park/Trails</a> .....	47
4.10.8 - <a href="#">Quarries</a> .....	47
4.10.9 - <a href="#">Residential Uses in a Commercial Zoning District</a> .....	48
4.10.10 - <a href="#">Wind Energy Conversion Systems</a> .....	49
4.10.11 - <a href="#">Uses Subject to Conditional Use</a> .....	51
Section 4.11 - <a href="#">Condominium Subdivision Plan Approval</a> .....	52
Section 4.12 – <a href="#">Amendment Procedures</a> .....	56
<b>ARTICLE V - <a href="#">TOWNSHIP ZONING BOARD OF APPEALS</a></b> .....	<b>57</b>
Section 5.1 - <a href="#">Township Zoning Board of Appeals</a> .....	57
Section 5.2 - <a href="#">Duties of the Township Zoning Board of Appeals</a> .....	57
Section 5.3 - <a href="#">Variance</a> .....	57
Section 5.4 - <a href="#">Interpretation of Zoning Ordinance</a> .....	59
Section 5.5 - <a href="#">Appeals to the Township Zoning Board of Appeals</a> .....	59
<b>ARTICLE VI - <a href="#">DEFINITIONS AND UNDEFINED TERMS</a></b> .....	<b>61</b>
Section 6.1 - <a href="#">Definitions</a> .....	61
Section 6.2 - <a href="#">Illustrations</a> .....	70
Section 6.3 - <a href="#">Undefined Terms</a> .....	71

	Page
<b>ARTICLE VII - <u>LEGAL STATUS</u></b> .....	73
Section 7.1 - <u>Conflict with Other Laws</u> .....	73
Section 7.2 - <u>Validity and Severability Clause</u> .....	73
Section 7.3 - <u>Period of Effectiveness</u> .....	73
Section 7.4 - <u>Repeal of Ordinance</u> .....	73
Section 7.5 - <u>Effective Date</u> .....	73

## **Article I IN GENERAL**

### **Section 1.1 – ENACTING CLAUSE**

Township of Somerset Zoning Ordinance adopted under authority of, and in accordance with, the provisions of the Michigan Zoning Enabling Act (PA 110 of 2006, [MCL 125.3101 et. seq.](#)) as amended to establish comprehensive zoning regulations for the Township of Somerset, County of Hillsdale, State of Michigan, and to provide for the administration, enforcement and amendment thereof, and the repeal of all Zoning Ordinances in conflict herewith.

### **Section 1.2 – TITLE**

This Zoning Ordinance shall be known and may be cited as the “Township of Somerset Zoning Ordinance”. The Zoning Map referred to herein is entitled the “Township of Somerset Official Zoning Map.”

### **Section 1.3 – PURPOSES**

This Zoning Ordinance has been established for the purpose of:

- a. Promoting and protecting the public health, safety, and general welfare;
- b. Protecting the character and stability of the agricultural, recreational, residential, commercial, and industrial areas, and promoting the orderly and beneficial development of such areas;
- c. Preventing the overcrowding of land and undue concentration of population by regulating the intensity of use of land and the area of open land surrounding Buildings/Structures necessary to provide adequate light, air, and privacy to protect the public health;
- d. Lessing and avoiding congestion on public roads;
- e. Providing for the needs of agriculture, recreation, residence, commerce, and industry in future growth to conform with the most advantageous use of land, resources, and properties, with reasonable consideration of other things, the general and appropriate trend and character of land, Buildings/Structures, and population development as studied and recommended by the Township Planning Commission and the Township of Somerset.
- f. Encouraging the most appropriate use of land in accordance with their character and adaptability, and prohibiting uses which are incompatible with the character of development permitted within specified Zoning Districts;
- g. Conserving the taxable value of land and Buildings/Structures;
- h. Conserving the expenditure of funds for public improvements and services;
- i. Protecting against fire, explosion, noxious fumes and odors, heat, dust, smoke, glare, noise, vibration, radioactivity, and other nuisances and hazards;

- j. Providing for the completion, restoration, reconstruction, extension or substitution of Nonconformities.

**Section 1.4 - SCOPE**

Every Building/Structure erected, every Use of any Lot or Building/Structure established, every structural alteration or relocation of an existing Building/Structure occurring, and every enlargement of or addition to an existing Use or Building/Structure occurring after the effective date of the Zoning Ordinance shall be subject to all regulations of the Zoning Ordinance, which are applicable in the Zoning Districts in which such Building/Structure, or Lot is located.

To avoid undue hardship, nothing in this Zoning Ordinance shall be deemed to require a change in the plans, construction, or designated Use of any Building/Structure on which actual construction was lawfully begun prior to the effective date of adoption or amendment of this Zoning Ordinance, provided that construction shall be completed within 365 days of such effective date and be subject thereafter to the provisions of [Section 4.7](#) of this Zoning Ordinance.

The adoption of this Zoning Ordinance shall not limit the construction of any Building/Structure for which a zoning permit has been obtained prior to the effective date of adoption or amendment of this Zoning Ordinance even though such Building/Structure does not conform to the provisions of this Zoning Ordinance provided that work commence and be carried on within 30 days of obtaining such permit and be subject thereafter to the provisions of [Section 4.7](#).

**Section 1.5 - APPLICATION OF REGULATIONS**

The regulations established by this Zoning Ordinance within each Zoning District shall be the minimum regulations for promoting and protecting the public health, safety, and general welfare and shall not preclude the establishment of higher or more restrictive standards or regulations for the authorization of any Conditional Use Permit, where such higher or more restrictive standards or regulations are found necessary by the Township Planning Commission to attain the purposes of this Zoning Ordinance.



## **Article II**

### **ZONING DISTRICTS**

#### **Section 2.1 – ESTABLISHMENT OF ZONING DISTRICTS**

The Township of Somerset is hereby divided into the following Zoning Districts:

- AG-1 Agricultural District
- RNF-1 Rural Non-Farm Residential District
- RL-1 Lake Residential District
- RS-1 Suburban Residential District
- RM-1 Multiple-Family Residential District
- C-1 General Commercial District
- C-2 Highway Service Commercial District
- I-I Light Industrial District

#### **Section 2.2 – TOWNSHIP OF SOMERSET OFFICIAL ZONING MAP**

The Zoning Districts as provided in [Section 2.1](#) of this Zoning Ordinance are bounded and defined on a map entitled, “Township of Somerset Official Zoning Map” which map, with all explanatory matter hereon, is hereby adopted as a part of this Zoning Ordinance.

- 2.2.1 **Identification of Township of Somerset Official Zoning Map:** The Township of Somerset Official Zoning Map shall be identified by the signature of the Township Supervisor, attested by the Township Clerk. The Township of Somerset Official Zoning Map shall be located in the office of the Township Clerk and available for examination.

#### **Section 2.3 – INTERPRETATION OF ZONING DISTRICT BOUNDARIES**

Except where specifically designated on the Township of Somerset Official Zoning Map, the Zoning District boundary lines are intended to follow Lot lines, the center lines of roads or alleys, the center lines of creeks, streams, or rivers, the center lines of projected roads or alleys, center lines of railroad rights-of-way lines, section lines, one-quarter section lines, one-eighth section lines, or a corporate limit line, all as they existed at the time of the enactment of this Zoning Ordinance, as subsequently modified and designated as such boundary line. Where a Zoning District boundary does not coincide with any of the above lines, the Zoning District boundary lines shall be dimensioned on the Township of Somerset Official Zoning Map.

When the location of a Zoning District boundary is uncertain, the Township Zoning Board of Appeals shall interpret the exact location of the Zoning District boundary.

#### **Section 2.4 – ZONING DISTRICTS REGULATIONS**

The intent, Permitted Uses, Conditional Uses, height, area, density, and other regulations of each Zoning District are set forth in this Article II.

- 2.4.1 **Agricultural Zoning Districts.** Any Agricultural District is established to protect land best suited for Agricultural Use from the encroachment of incompatible land Uses, to preserve valuable agricultural land for Agricultural Uses, and to retain land suited for open land and recreation Use for the future.

- a. **Agricultural District (AG-1):** The intent of this Zoning District is to set aside land suitable for agricultural development and agricultural related Uses.
  - 1. **Permitted Uses.** See [Section 2.5](#).
  - 2. **Conditional Uses.** See [Section 2.5](#).
  - 3. **Area, Yard, Height, and Bulk Regulations.** See [Section 2.6](#).

2.4.2 **Residential Zoning Districts.** The Rural Non-Farm Residential District, Lake Residential District, Suburban Residential District, and Multiple-Family Residential District are designated principally for Residential Use and are limited to Dwellings and Uses normally associated with residential neighborhoods in order to encourage a suitable and healthy environment for home life. The Residential Zoning Districts are designed to regulate the location of Residential Uses and Dwellings according to a well-considered plan which reflects the different types of Residential Uses and Dwellings, the different densities of population and the intensity of land Use desired; potential nuisances and hazards which may cause unhealthy conditions; and the relationship of Residential Uses and Dwellings to other areas and areas devoted to Agricultural, Commercial, or Industrial Use and to roads. The purpose of each Residential Zoning District is further stated below.

- a. **Rural Non-Farm Residential District (RNF-1):** This Zoning District is established to provide suitable areas for 1-Family Dwellings at low densities to preserve a predominantly rural character in these areas fit for concentrated Residential Use because of the ability of the soil to absorb sewage wastes from individual septic tanks.
  - 1. **Permitted Uses.** See [Section 2.5](#).
  - 2. **Conditional Uses.** See [Section 2.5](#).
  - 3. **Area, Yard, Height, and Bulk Regulations.** See [Section 2.6](#).
- b. **Suburban Residential District (RS-1):** This Zoning District is designed to provide areas principally for high-density 1-Family Dwellings where necessary urban services and facilities can be feasibly provided, including central sanitary and central water systems.
  - 1. **Permitted Uses.** See [Section 2.5](#).
  - 2. **Conditional Uses.** See [Section 2.5](#).
  - 3. **Area, Yard, Height, and Bulk Regulations.** See [Section 2.6](#).
- c. **Lake Residential District (RL-1):** This Zoning District is designed to preserve and enhance areas which are suitable for lakefront residential development, principally 1-Family Dwellings at moderate densities, with consideration to protecting the lake waters from potential pollutants.
  - 1. **Permitted Uses.** See [Section 2.5](#).
  - 2. **Conditional Uses.** See [Section 2.5](#).
  - 3. **Area, Yard, Height, and Bulk Regulations.** See [Section 2.6](#).

- d. **Multiple-Family Residential District (RM-1):** This Zoning District is designed to permit a high density of population and a high density of land Use in those areas which are served by a central water supply system and a central sanitary sewer system, and which abut or are adjacent to such other Uses or amenities which support, complement or serve such a density and intensity.
  - 1. **Permitted Uses.** See [Section 2.5](#).
  - 2. **Conditional Uses.** See [Section 2.5](#).
  - 3. **Area, Yard, Height, and Bulk Regulations.** See [Section 2.6](#).

2.4.3 **Commercial Zoning Districts.** The General Commercial District, and Highway Service Commercial District are designed to limit compatible commercial enterprises at appropriate locations to encourage efficient traffic movement, parking and utility services; advance public safety; and protect surrounding property. The Commercial Zoning Districts are designed to regulate the locations of these Commercial Uses according to a well-considered plan which determined the types of such Uses and the intensity of land, and roads in each such Zoning District; potential nuisances and hazards which may cause unsafe conditions; and the relationship of Commercial Uses to each other and to other areas devoted to Agricultural, Residential, or Industrial Use and to roads. The purpose of each Commercial Zoning District is further stated below.

- a. **General Commercial District (C-1):** This Zoning District is intended to encourage planned and integrated groupings of retail, service, and administrative establishments which will provide retail convenience and comparison goods and provide personal and professional services for the entire area and to accommodate commercial establishments which cannot be practically provided in another commercial area.
  - 1. **Permitted Uses.** See [Section 2.5](#).
  - 2. **Conditional Uses.** See [Section 2.5](#).
  - 3. **Area, Yard, Height, and Bulk Regulations.** See [Section 2.6](#).
- b. **Highway Service Commercial District (C-2):** This Zoning District is intended to provide various commercial establishments offering accommodations, supplies, and services to local as well as through motorized vehicle traffic. This Zoning District should be provided at locations along major thoroughfares and discourage dispersion of these activities.
  - 1. **Permitted Uses.** See [Section 2.5](#).
  - 2. **Conditional Uses.** See [Section 2.5](#).
  - 3. **Area, Yard, Height, and Bulk Regulations.** See [Section 2.6](#).

2.4.4 **Industrial Zoning Districts.** It is recognized by the Zoning Ordinance that the value to the public of designating certain areas for certain type of Industrial Uses is represented in the employment opportunities afforded to citizens and the resultant economic benefits conferred upon the Township of Somerset. In order that this value may be maintained and this Use encouraged, this Zoning Ordinance established one Zoning District designed to regulate the location of Industrial Uses according to a well-considered plan which reflects the types of such Uses and the intensity of land, and roads in each such Zoning District; potential nuisances and hazards which may cause unsafe and unhealthy conditions; and the relationship of Industrial Uses to each and to other areas devoted to Agricultural, Residential, or Commercial Use and to roads and other means of transportation. To these ends, certain Uses which would function more effectively

in other Zoning Districts and would interfere with the operation of these industrial activities and the purpose of these Zoning Districts have been excluded. The purpose of this Industrial Zoning District is further stated below.

- a. **Light Industrial District (I-1):** This Zoning District is designed to provide suitable space for Light Industrial Uses which operate in a safe, non-objectionable and efficient manner, and which are compatible in appearance with and require a minimum of buffering measures from adjoining nonindustrial Zoning Districts. These Uses generate a minimum of noise, glare, odor, dust, vibration, air and water pollutants, fire, explosive and radioactive hazards, and other harmful or obnoxious matter.
  1. **Permitted Uses.** See [Section 2.5](#).
  2. **Conditional Uses.** See [Section 2.5](#).
  3. **Area, Yard, Height, and Bulk Regulations.** See [Section 2.6](#).

**Section 2.5 – TABLES OF PERMITTED AND CONDITIONAL USES**

The tables in this Section 2.5 contain the various Uses permitted (P), or allowed conditionally (C) within the indicated Zoning Districts. Conditional Uses require approval by the Township Board of Trustees upon the recommendation of the Township Planning Commission according to the procedures of [Section 4.9](#).

**2.5.1 Agricultural Uses**

	AG-1	RNF-1	RL-1	RS-1	RM-1	C-1*	C-2*	I-1*
General and specialized farming and agricultural activities except feedlots, but including the raising or growing and storage or preservation of crops, sod, livestock, poultry, rabbits, fur-bearing animals, and other farm animals, and plants, trees, shrubs, and nursery stock.	P							
Sale of agricultural products raised or grown on the farm premises including roadside stand for said sales.	P							
Commercial feedlots, only in accordance with the regulations specified in <a href="#">Section 4.8.1c</a> .	C							
Sanitary landfills, only in accordance with the regulations specified in <a href="#">Section 4.8.1c</a> .	C							
Accessory Uses or Buildings/Structures—agricultural.	P							

\*Only in accordance with the regulations specified in [Section 4.8.1i](#).

**2.5.2 Residential Uses**

	AG-1	RNF-1	RL-1	RS-1	RM-1	C-1*	C-2*	I-1*
1-Family Dwellings.	P	P	P	P	P			
2-Family Dwellings.					P			

	AG-1	RNF-1	RL-1	RS-1	RM-1	C-1*	C-2*	I-1*
Multiple-Family Dwellings, only in accordance with the regulations specified in <a href="#">Section 4.8.1a</a>					P			
Rooming houses and boarding houses, only in accordance with the regulations specified in <a href="#">Section 4.8.1c</a> .					C			
Mobile home parks, only in accordance with the regulations specified in <a href="#">Section 4.10.5</a> , <a href="#">Section 4.8.1b</a> , and <a href="#">Section 4.8.1c</a> .					C			
Mobile home subdivisions, only in accordance with the regulations specified in <a href="#">Section 4.10.6</a> and <a href="#">Section 4.8.1c</a> .					C			
Site condominiums, only in accordance with the regulations specified in <a href="#">Section 4.8.1f</a> .	P	P	P	P	P			
Subdivision plats, only in accordance with the regulations specified in <a href="#">Section 4.8.1g</a> .	P	P	P	P	P			
Accessory Uses or Buildings/Structures—residential.	P	P	P	P	P			
Residential Uses subject to a Conditional Use Permit, only in accordance with the regulations specified in <a href="#">Section 4.10.11</a> .		P	P	P	P			
Residential Uses in Commercial Zoning Districts, only in accordance with the regulations specified in <a href="#">Section 4.10.9</a> .						P	P	P
Funneling, only in accordance with the regulations specified in <a href="#">Section 4.10.3</a> and <a href="#">Section 4.8.1c</a> .	C	C	C	C	C			
Home occupations, only in accordance with the regulations specified in <a href="#">Section 3.11</a> .	P	P	P	P	P			

\*Only in accordance with the regulations specified in [Section 4.8.1i](#).

### 2.5.3 Commercial Uses<sup>†</sup>

	AG-1	RNF-1	RL-1	RS-1	RM-1	C-1*	C-2*	I-1*
Adult Entertainment, only in accordance with the regulations specified in <a href="#">Section 4.8.1c</a> and Township of Somerset Ordinance #34.							C	C
Bed and Breakfast Facilities, only in accordance with the regulations specified in <a href="#">Section 4.10.1</a> .	P	P	P	P	P			
Business schools; including dance schools, music schools, and art schools.						P	P	
Business services including banks, loan offices, real estate offices, and insurance offices.						P	P	
Drive-in business services, only in accordance with the regulations specified in <a href="#">Section 4.8.1c</a> .						C		
Drive-in retail and service establishments, except drive-in theaters, only in accordance with the regulations specified in <a href="#">Section 4.8.1d</a> .							P	
Drive-in theaters, only in accordance with the regulations specified in <a href="#">Section 4.10.2</a> and <a href="#">Section 4.8.1c</a> .							C	



	AG-1	RNF-1	RL-1	RS-1	RM-1	C-1*	C-2*	I-1*
Eating and drinking establishments, but not including drive-in types, only in accordance with the regulations specified in <a href="#">Section 4.8.1c</a> (where applicable).						P	P	
Eating and drinking establishments, including drive-in types.							P	
Farm machinery and equipment sales and repair.								P
Hotels and motels, only in accordance with the regulations specified in <a href="#">Section 4.8.1c</a> (where applicable).						C	P	
Indoor retail sales establishments.						P	P	
Offices of an executive, administrative, or professional nature, only in accordance with the regulations specified in <a href="#">Section 4.8.1c</a> (where applicable).					C	P	P	
Office buildings associated with a Light Industrial Use.								P
Personal services, including barber shops and beauty salons; medical and dental clinics; dry cleaners and self-serve laundromats; and sale repair shops for watches, shoes, radios and televisions.						P	P	
Printing establishments.						P	P	
Retail sale of foods, drugs, hardware, notions, books, and similar convenience goods.						P	P	
Sales, rental, and service of motor vehicles, trailers, and boats.							P	
Accessory Uses or Buildings/Structures—commercial.	P					P	P	

†Only in accordance with the regulations specified in [Section 4.8.1d](#) (where applicable).

\*Only in accordance with the regulations specified in [Section 4.8.1i](#).

#### 2.5.4 Light Industrial Uses<sup>†</sup>

	AG-1	RNF-1	RL-1	RS-1	RM-1	C-1*	C-2*	I-1*
Assembly and manufacture, from prefabricated parts, of household appliances, electronic products, machinery and hardware products, and similar products; or the processing or assembling of parts for production of finished equipment.								P
Vehicle repair garages, only in accordance with the regulations specified in <a href="#">Section 4.8.1c</a> (where applicable).							C	
Vehicle service stations, only in accordance with the regulations specified in <a href="#">Section 4.8.1c</a> (where applicable).						C	P	
Contractor's yard.								P
General service and repair establishments including dyeing, cleaning, or laundry works and upholstery or appliance repair.								P

	AG-1	RNF-1	RL-1	RS-1	RM-1	C-1*	C-2*	I-1*
Generally including those Light Industrial Uses similar to the Permitted Uses in this Zoning District which do not create any more danger to health and safety in surrounding areas and which do not create any more offensive noise, vibration, smoke, dust, line, odors, heat, or glare than that which is generally associated with light industries of the type specifically permitted, only in accordance with the regulations specified in <a href="#">Section 4.8.1c</a> (where applicable).								C
Junk yard, only in accordance with the regulations specified in <a href="#">Section 4.10.4</a> .								P
Lumber yard.								P
Mini-Storage or Self-Storage								P
Research and testing laboratories.								P
Sawmill								P
Sawmill in conjunction with general and specialized farming	P							
Skilled trade services including plumbing, electric, heating, printing and painting establishments.								P
Trucking terminals.								P
Vehicle repair garages, but not including vehicle junk yards.								P
Wholesale merchandising or storage warehouses.								P

†Only in accordance with the regulations specified in [Section 4.8.1e](#) (where applicable).

\*Only in accordance with the regulations specified in [Section 4.8.1i](#).

### 2.5.5 Educational, Childcare, Health Care, and Animal Care Uses

	AG-1	RNF-1	RL-1	RS-1	RM-1	C-1*	C-2*	I-1*
Convalescent homes, nursing homes, hospitals, sanitariums and orphanage, only in accordance with the regulations specified in <a href="#">Section 4.8.1c</a> .	C				C			
Funeral establishments or homes, only in accordance with the regulations specified in <a href="#">Section 4.8.1c</a> (where applicable)..					C	P	P	
Medical and dental clinics, only in accordance with the regulations specified in <a href="#">Section 4.8.1c</a> .					C			
Medical marijuana caregiver grow operation, only in accordance with the regulations specified in <a href="#">Section 3.12.1</a>								P
Medical marijuana home use in permitted Dwellings and legally nonconforming Dwellings, only in accordance with the regulations specified in <a href="#">Section 3.12.2</a>	P	P	P	P				P

	AG-1	RNF-1	RL-1	RS-1	RM-1	C-1*	C-2*	I-1*
Animal hospitals and small animal clinics, only in accordance with the regulations specified in <a href="#">Section 4.8.1c</a> .	C					C		
Kennels.	P							
Public and private nurseries, primary and secondary non-profit schools, and colleges and universities, only in accordance with the regulations specified in <a href="#">Section 4.8.1c</a> .	C				C			
Public and private nurseries and primary and secondary non-profit schools, only in accordance with the regulations specified in <a href="#">Section 4.8.1c</a> .	C	C	C	C	C			
State licensed group day-care centers, only in accordance with the regulations specified in <a href="#">Section 4.8.1c</a> .								
Riding academies and stables, only in accordance with the regulations specified in <a href="#">Section 4.8.1c</a> .	C							

\*Only in accordance with the regulations specified in [Section 4.8.1i](#).

## 2.5.6 Recreational Uses

	AG-1	RNF-1	RL-1	RS-1	RM-1	C-1*	C-2*	I-1*
Clubs and lodges, only in accordance with the regulations specified in <a href="#">Section 4.8.1d</a> .						P	P	
Commercially operated ORV (off-road vehicles) parks/trails, only in accordance with the regulations specified in <a href="#">Section 4.10.7</a> and <a href="#">Section 4.8.1c</a> and <a href="#">Section 4.8.1d</a> .	C							
Conservation and/or recreation areas including forest preserves, game refuges, nature reservations, hunt clubs, and similar areas of low intensity use.	P							
Country clubs; private swimming pools; recreation centers, and parks; playgrounds, and playfields, only in accordance with the regulations specified in <a href="#">Section 4.8.1c</a> .		C	C					
Golf courses, only in accordance with the regulations specified in <a href="#">Section 4.8.1c</a> and <a href="#">Section 4.8.1d</a> (where applicable).	C							
Golf courses, but not including golf driving ranges, only in accordance with the regulations specified in <a href="#">Section 4.8.1c</a> and <a href="#">Section 4.8.1d</a> (where applicable).		C	C					
Golf driving ranges, only in accordance with the regulations specified in <a href="#">Section 4.8.1c</a> (where applicable) and <a href="#">Section 4.8.1d</a> (where applicable).	C							
Group or organized camps, camping grounds, and general or specialized resorts, only in accordance with the regulations specified in <a href="#">Section 4.8.1c</a> and <a href="#">Section 4.8.1d</a> (where applicable).	C							
Indoor commercial amusement and recreation services, including theaters, bowling alleys, and roller and ice skating rinks, only in accordance with the regulations specified in <a href="#">Section 4.8.1d</a> .						P	P	
Marinas, only in accordance with the regulations specified in <a href="#">Section 4.8.1c</a> and <a href="#">Section 4.8.1d</a> (where applicable).								



	AG-1	RNF-1	RL-1	RS-1	RM-1	C-1*	C-2*	I-1*
Parks and playgrounds, only in accordance with the regulations specified in <a href="#">Section 4.8.1c</a> .			C					
Public swimming pools, recreation centers, parks, playgrounds and playfields, only in accordance with the regulations specified in <a href="#">Section 4.8.1c</a> and <a href="#">Section 4.8.1d</a> (where applicable).				C	C			
Travel trailer parks, only in accordance with the regulations specified in <a href="#">Section 4.8.1c</a> and <a href="#">Section 4.8.1d</a> (where applicable).	C							

\*Only in accordance with the regulations specified in [Section 4.8.1i](#).

## 2.5.7 Institutional and Infrastructure Uses

	AG-1	RNF-1	RL-1	RS-1	RM-1	C-1*	C-2*	I-1*
Religious institutions, only in accordance with the regulations specified in <a href="#">Section 4.8.1c</a> .	C	C	C	C	C	C		
Government- or community-owned Buildings/Structures, but not including schools, only in accordance with the regulations specified in <a href="#">Section 4.8.1c</a> .			C	C	C	C		
Cemeteries, only in accordance with the regulations specified in <a href="#">Section 4.8.1c</a> .	C							
Airports, only in accordance with the regulations specified in <a href="#">Section 4.8.1c</a> .	C							
Quarries, only in accordance with the regulations specified in <a href="#">Section 4.10.8</a> and <a href="#">Section 4.8.1c</a> .	C							
Essential service Buildings/Structures of a non-industrial character, but not including maintenance depots or warehouses, only in accordance with the regulations specified in <a href="#">Section 4.8.1c</a> .		C	C	C	C			
Essential services and Buildings/Structures of a non-industrial character, but not including maintenance depots and warehouses only in accordance with the regulations specified in <a href="#">Section 3.8</a> and <a href="#">Section 4.8.1c</a> .	P	P	P	P	P	P	P	
Essential services and Buildings/Structures, only in accordance with the regulations specified in <a href="#">Section 3.8</a> .								P
Communication Towers, only in accordance with the regulations specified in <a href="#">Section 4.8.1c</a> .	C	C				P	P	C
Radio and microwave towers.	C							
Wind Energy Conversion Systems, only in accordance with the regulations specified in <a href="#">Section 4.10.10</a> and <a href="#">Section 4.8.1c</a> .	C	C	C	C		C	C	C

\*Only in accordance with the regulations specified in [Section 4.8.1i](#).

**Section 2.6 – ZONING DISTRICT AREA, YARD, HEIGHT, AND BULK REGULATIONS**

Zoning District	Zoning Symbol	Lot Regulations			Min. Yard Setbacks			Max. Bldg. Height		Minimum Transition Strip Regulations	
		Min. Lot Area	Min. Lot Width	Max. Lot Coverage	Front	Side	Rear	Principal	Accessory		
Agricultural	AG-1	1 Acre	120 ft.	30%	35 ft.	10 ft. 25 ft. tot. 35 ft. (1)	20 ft.	2½ story or 35 ft.	80 ft.		
Rural Non-Farm Residential	RNF-1	1 Acre	120 ft.	30%	35 ft.	10 ft. 25 ft. tot. 35 ft. (1)	20 ft.	2½ story or 35 ft.	25 ft.		
Suburban Residential	RS-1	10,000 sq. ft.	60 ft.	30%	25 ft.	6 ft. 12 ft. tot.	25 ft.	2½ story or 35 ft.	25 ft.		1-Family Dwellings with central sewerage and water systems.
		15,000 sq. ft.	120 ft.								1-Family Dwellings without central sewerage and water systems
		1 Acre	120 ft.								All other Uses (2)
Lake Residential	RS-1	7,500 sq. ft.	60 ft.	30%	25 ft.	6 ft. 12 ft. tot.	25 ft.	2½ story or 35 ft.	25 ft.		1-Family Dwellings
		1 Acre	120 ft.								All other Uses (2)
Multiple-Family Residential	RM-1	5,000 sq. ft.	30 ft.	50%	10 ft.	10% of Lot width or 6 ft. – whichever is greater	10 ft.	2½ story or 35 ft.	25 ft.		1-Family Dwellings
		10,000 sq. ft.	80 ft.	25%	25 ft.	10 ft. 25 ft. tot. 35 ft. (1)	25 ft.	2½ story or 35 ft.	25'		2-Family Dwellings with central sewerage and water systems.
		15,000 sq. ft.	120 ft.								2-Family Dwellings without central sewerage and water systems
		15,000 sq. ft.	120 ft.								15,000 sq. ft. for 1 <sup>st</sup> 3 Dwellings plus 2,000 sq. ft. for each additional Dwelling
		½ Acre	120 ft.								All other Uses (2)

Zoning District	Zoning Symbol	Lot Regulations			Min. Yard Setbacks			Max. Bldg. Height		Minimum Transition Strip Regulations	
		Min. Lot Area	Min. Lot Width	Max. Lot Coverage	Front	Side	Rear	Principal	Accessory		
General Commercial	C-1	10,000 sq. ft.	75 ft.	25%	35 ft.	25 ft. tot. 35 ft. (1)	20 ft.	35 ft.		15 ft. wide and fence, wall, or hedge 4 ft. to 6 ft. height is abutting a Residential Zoning District. 20 ft. wide landscaped strip if fronting a public road.	With central sewerage and water systems.
		15,000 sq. ft.	100 ft.							Without central sewerage and water systems	
Highway Service Commercial	C-2	15,000 sq. ft.	100 ft.	25%	35 ft.	25 ft. tot. 35 ft. (1)	20 ft.	35 ft.		15' wide and fence, wall, or hedge 4' to 6' height is abutting a Residential Zoning District. 20 ft. wide landscaped strip if fronting a public road.	
Light Industrial	I-1	20,000 sq. ft.	80 ft.	50%	35 ft.	25 ft. tot. 35 ft. (1)	35 ft.	35 ft.		15 ft. wide and fence, wall, or hedge 4 ft. to 6 ft. height is abutting a Residential Zoning District. 20 ft. wide landscaped strip if fronting a public road.	

(1) Corner Lot, side yard requirement on road side of Lot.

(2) No Accessory Buildings/Structures permitted without a Principal Building/Structure on the property.

### 2.6.1 Compliance with Regulations:

- a. Notwithstanding the regulations of [Section 2.6](#), in General Commercial Zoning Districts, the Township Zoning Administrator and/or the Township Zoning Board of Appeals and/or the Township Board of Trustees may permit Lots to be not less than 20 feet wide and Lots to contain an area not less than 1,500 square feet only in instances where such Lots are contained within a platted subdivision which is irrevocably dedicated for Commercial Uses and where central sewerage and water systems are available.
- b. No yard or Lot existing at the time of passage of this Zoning Ordinance shall be reduced in dimension or area below the minimum regulations set forth for the Zoning District in which the yard or Lot is located. Yards or Lots created after the effective date of this Zoning Ordinance shall meet at least the minimum regulations established by this Zoning Ordinance.

- c. No part of a yard or other open land required for or in connection with any Building/Structure (for the purpose of complying with this Zoning Ordinance) shall be included as part of a yard or open land similarly required for any other Building/Structure.

2.6.2 **Yard Measurements:**

- a. Lots which abut on more than one road shall provide the required front yards along every road.
- b. All front, side and rear yards shall be the minimum perpendicular distance measured from the Lot line to the Principal Building/Structure, excluding all projections not exceeding 3 feet in length from the Building/Structure wall.
- c. A 3-sided Lot shall be considered to have a front and 3 sides. The road Lot line will be considered the front line except on a Lot abutting the water; then the front will be interpreted to be the water side.

2.6.3 **Lot Width:** The width of a Lot shall be considered to be the distance between straight lines connecting front and rear Lot lines at each side of the Lot, measured across the rear of the required front yard; provided however, that width between side Lot lines at their foremost points (where they intersect with the road line) shall not be less than 80% of the required Lot width, except in the case of Lots on the turning circle of cul-de-sacs, where the 80% regulations shall not apply.

2.6.4 **Height Exceptions:** The limitations affecting the height of Building/Structures shall not apply to the following appurtenant appendages and Buildings/Structures provided they comply with all other provisions of this Zoning Ordinance or other applicable Ordinances; parapet walls, chimney, smokestacks, religions institution spires, flagpoles, radio and television towers, penthouses for mechanical equipment, water tanks, anemometers and wind energy conversion systems.

2.6.5 **Increased Height:** Building/Structure height in excess of the height above average ground level allowed in any Zoning District may be permitted provided all minimum front, side, and rear yard depths are increased 1 foot for each additional 1 foot of height and provided that adequate fire protection can be demonstrated.

2.6.6 **Accessory Building/Structure:**

a. **General**

1. Accessory Building/Structure in all Zoning Districts except AG-1 Agricultural shall be subject to the regulations in this Section 2.6.6, except as otherwise specified in this Zoning Ordinance.
2. Reserved.
3. Accessory Buildings/Structures shall be customarily incidental and subordinate to the existing Principal Building/Structure or Use permitted and existing on the site.
4. Accessory Buildings/Structures include, but are not limited to, garages, carports, pole barns and storage sheds, which shall be constructed for permanent use and of materials which the Township Zoning Administrator determines are normally recognized building materials for the type of Accessory Building/Structure being constructed.
5. Mobile homes, portable Buildings/Structures, Buildings/Structures constructed of fabric or vinyl, vehicles and trailers, shall not be considered Accessory Buildings/Structures and are not permitted to be used as garages or Accessory Buildings/Structures.

6. Permit-required: Any Accessory Building/Structure shall require a Zoning Compliance Permit, except 1 Accessory Building/Structure under 150 square feet shall be allowed without a Zoning Compliance Permit.
7. Required setbacks: A detached Building/Structure less than 150 square feet of total floor area shall be at least 4 feet from any Principal Building/Structure, and at least 4 feet from any property line.
8. Restrictions in front yard: An Accessory Building/Structure shall not be erected in any front yard, except an Accessory Building/Structure is permitted in the front yard on waterfront Lots in the RL-1 District.
9. Shoreline Lots: a separate deck or patio of 200 square feet or less shall be permitted along the waterside property line, with a maximum length along the waterside property line of 20 feet and a maximum height of 24 inches above average grade. Lots with boundary lines located in the water, deck or patio may be constructed within 4 feet of the ordinary high-water mark of the lake or stream.

b. **Area, Height and Number Limitations.**

1. No detached Accessory Building/Structure shall be located closer than 10 feet to any other Building/Structure.
2. Yard regulations for Residential Zoning Districts:
  - (a) In no instance shall such Building/Structure be near the side yard or rear Lot line than as referred in [Section 2.6](#).
  - (b) Detached garages in Residential Zoning Districts may be located in the side yard, providing setback regulations for the Principal Building/Structure are maintained.
  - (c) In the case of lakefront property, an Accessory Building/Structure is permitted in the front yard, provided the same front and side yard setbacks required for a Principal Building/Structure in the property are complied with.
3. All Accessory Buildings/Structures in Commercial and Industrial Zoning Districts shall be subject to the same standards and regulations for Principal Buildings/Structures.
4. An Accessory Building/Structure shall not occupy more than 25% of a required rear yard, not more than 40% of any non-required rear yard. In no instance shall the ground floor area of any Accessory Building/Structure exceed 150% of the Principal Building/Structure in any regulated Zoning District.
5. No Accessory Building/Structure shall be constructed prior to the commencement of its Principal Building/Structure.

2.6.7 **Distance Between Grouped Buildings:** In addition to the required setback lines provided elsewhere in this Zoning Ordinance, in grouped Buildings/Structures (including Multiple-Family Dwellings) the following minimum distances shall be required between each said Dwelling.

- a. Where Buildings/Structures are front to front or front to rear, 3 times the height of the taller Building, but not less than 70 feet.
- b. Where Buildings/Structures are side to side, 1 times the height of the taller Building but not less than 20 feet.

- c. Where Buildings/Structures are front to side, rear to side, or rear to rear, 2 times the height of the taller Building but not less than 45 feet.

## **Article III**

### **SUPPLEMENTAL REGULATIONS**

#### **Section 3.1 – PURPOSE**

It is the purpose of this Article III of this Zoning Ordinance to provide regulations and regulations that supplement the provisions contained under the respective Zoning District regulations in Article II, and may not apply in all Zoning Districts.

#### **Section 3.2 - RESERVED**

#### **Section 3.3 – ACCESS TO PUBLIC ROADS**

- 3.3.1 In any Residential Zoning District, Commercial Zoning District, and Industrial Zoning District, every Building/Structure or Use established after the effective date of this Zoning Ordinance shall be on a Lot or parcel which adjoins a public road.
- 3.3.2 In any Agricultural Zoning District every Building/Structure or Use established after the effective date of this Zoning Ordinance shall be on a Lot or parcel which adjoins a public or private easement of access to a public road.

#### **Section 3.4 – CURB CUTS AND DRIVEWAYS**

Curb cuts and driveways may be located only upon approval by the Township Zoning Administrator and such other county and Michigan authorities as required by law; provided however, such approval shall not be given where such curb cuts and driveways shall unnecessarily increase traffic hazards.

#### **Section 3.5 – VISIBILITY AT INTERSECTIONS**

On any corner Lot in any Zoning Districts requiring front and side yards, no fence, wall, hedge, screen, sign, Building/Structure, vegetation, or planting shall be allowed to impede vision between a height of 3 feet and 8 feet above the centerline grades within the triangular area formed by the intersecting road right-of-way lines and a straight line joining the 2 road lines at points which are 30 feet distance from the point of intersection, measured along road right-of-way lines.

#### **Section 3.6 - OFF-ROAD PARKING REGULATIONS**

In all Zoning Districts, there shall be provided at the time of any Building/Structure or Use is established, enlarged, or increased in capacity, off-road parking spaces for motor vehicles with the regulations herein specified. Such off-road parking spaces shall be maintained and shall not be encroached upon by Buildings/Structures or other Uses so long as the Principal Building/Structure or Use remains, unless an equivalent number of such spaces are provided elsewhere in conformance with this Zoning Ordinance.

- 3.6.1 **Plans:** Plans and specifications showing required off-road parking spaces, including the means of access and interior circulation, shall be submitted to the Township Zoning Administrator for review at the time of application for a Zoning Compliance Permit for the erection or enlargement of a Building/Structure.
- 3.6.2 **Location of Off-Road Parking Areas:** Required off-road parking facilities shall be located on the same Lot as the Principal Building/Structure or on a Lot within 300 feet thereof except that this distance shall not exceed 150 feet for 1-Family Dwellings and 2-Family

Dwellings. This specified distance shall be measured from the nearest point of the Lot occupied by the Building/Structure or Use that such facility is required to serve.

3.6.3 **Reserved**

3.6.4 **Off-Road Parking Area Design:**

- a. Each off-road parking space for motorized vehicles shall be not less than 200 square feet in area, exclusive of access drives or aisles, and shall be of usable shape and condition.
- b. There shall be provided a minimum access drive of 10 feet in width, and where a turning radius is necessary, it will be of such an arc as to reasonably allow an unobstructed flow of traffic.
- c. Parking aisles for motorized vehicles shall be of sufficient width to allow a minimum turning movement in and out of parking spaces. The minimum width of such aisles shall be:
  1. For 90° or perpendicular parking, the aisle shall not be less than 22 feet in width.
  2. For 60° parking, the aisle shall be less than 18 feet in width.
  3. For 15° parking, the aisle shall not be less than 10 feet in width.
  4. For parallel parking, the aisle shall not be less than 10 feet in width.
- d. All off-road parking spaces shall not be closer than 5 feet to any property line, except where a wall, fence, or compact planting strip exists as a parking barrier along the property line.
- e. All on-road parking areas shall be drained so as to prevent drainage to abutting properties and shall be constructed of materials which have a dust-free surface resistant to erosion.
- f. Any lighting fixtures used to illuminate any off-road parking area shall be so arranged as to reflect the light away from any adjoining residential Lot or institution.
- g. Any off-road parking area providing space for 5 or more vehicles shall be effectively screened on any side which adjoins or faces property adjoining a residential Lot or institution, by a wall, fence, or compact planting not less than 4 feet in height. Plantings shall be maintained in good condition and not encroach on adjoining property.
- h. All off-road parking areas that make it necessary for vehicles to back out directly into a public road are prohibited, provided that this prohibition shall not apply to off-road parking areas of 1-Family Dwellings-or 2-Family Dwellings.

3.6.5 **Collective Parking:** Regulations for the provision of parking facilities with respect to 2 or more property Uses of the same or different types may be satisfied if the permanent allocation of the requisite number of spaces designated is not less than the sum of individual regulations.

3.6.6 **Determining Regulations:** For the purposes of determining off-road parking regulations the following units of measurement shall apply:



- a. **Floor Area:** In the case where floor area is the unit for determining the required number of off-road parking spaces, said unit shall mean the gross floor area, except that such floor area need not include any area used for parking within the Principal Building/Structure and need not include any area used for incidental service storage, installations of mechanical equipment, penthouse housing ventilators and heating systems, and similar uses.
- b. **Places of Assembly:** In stadiums, sports arenas, religious institutions, and other places of assembly in which those in attendance occupy benches, pews, or other similar seating facilities, every 24 inches of such seating shall be counted as 1 seat. In cases where a place of assembly has both fixed seats and open assembly area, regulations shall be computed separately for each type and added together.
- c. **Fractions:** When units of measurement determining the number of required parking spaces result in requirement of a fractional space, any fraction up to and including  $\frac{1}{2}$  shall be disregarded and fractions over  $\frac{1}{2}$  shall require 1 parking space.

3.6.7 **Schedule of Off-Road Parking Spaces:** The minimum required off-road parking spaces shall be set forth in the following Schedule of Off-Road Parking Spaces. Where a Use is not specifically mentioned, the parking regulations of a similar or related Use shall apply.

Use	Parking Space Regulations
Motorized Vehicle or Machinery Sales and Service Charges	1 space for each 200 square feet of showroom floor area plus 2 spaces for each service bay plus 1 space for each 2 employees.
Bank, Business and Professional Offices	1 space for each 200 square feet of gross floor area.
Barber Shops and Beauty Parlors	1 space for each chair plus 1 space for each employee.
Bowling Alleys	7 spaces for each bowling alley.
Dwelling Unit	2 spaces for each Dwelling Unit.
Funeral Homes and Mortuaries	4 spaces for each parlor or 1 space for each 50 square feet of floor area plus 1 space for each fleet vehicle, whichever is greater.
Furniture, Appliance Stores, Household Equipment and Furniture Repair Shops	1 space for each 400 square feet of floor area.
Hospitals	1 space for each bed excluding bassinets plus 1 space for each 2 employees.
Hotels, Motels, Lodging Houses, Boarding Homes	1 space for each living unit plus 1 space for each 2 employees.
Motorized Vehicle Service Stations	1 space for each 800 square feet of floor area plus 1 space for each 4 employees.
Manufacturing, Fabricating, Processing and Bottling Plants, Research and Testing Laboratories	1 space for each 2 employees on maximum shift.

Use	Parking Space Regulations
Medical and Dental Clinics	1 space for each 200 square feet of floor area plus 1 space for each employee.
Religious Institutions, Auditoriums, Stadiums, Sports Arenas, Theaters, Dance Halls, Assembly Halls other than schools.	1 space for each 4 seats.
Restaurants, Beer Parlors, Taverns, and Night Clubs	1 space for each 2 patrons of maximum seating capacity plus 1 space for each 2 employees.
Self-Service Laundry or Dry Cleaning Stores	1 space for each 3 washing and/or dry cleaning machines.
Private or Public Elementary and Junior High Schools	1 space for each employee normally engaged in or about the Building/Structure or grounds plus 1 space for each 30 students enrolled.
Private or Public Senior High School and Institution of Higher Learning	1 space for each employee in or about the Buildings/Structure or grounds plus 1 space for each 4 students enrolled.
Super Market, Self-Service Food and Discount Stores	1 space for each 200 square feet of floor area plus 1 space for each 2 employees.
Wholesale Establishments and Warehouses	1 space for each 400 square feet of floor area plus 1 space for each 2 employees.

**3.6.8 Exception:**

The parking regulations for all Uses proposed on a Lot shall be cumulative, unless the Township Planning Commission shall find that the parking regulations of a particular land use occur at different hours from those of other contiguous land uses, such that particular land use parking areas can be advantageously used during non-conflicting hours by the other contiguous land use, in which event the required parking spaces for such particular land use may be reduced by the Township Planning Commission to a minimum of the greatest number of spaces required for any of such contiguous land uses.

**Section 3.7 – OFF-ROAD LOADING AND UNLOADING REGULATIONS**

In connection with every Building/Structure or Use hereafter erected, except 1-Family Dwellings and 2-Family Dwellings which customarily receive or distribute material or merchandise by vehicle, there shall be provided on the same Lot with such Buildings/Structures, off-road loading and unloading space.

**3.7.1 Plans:**

Plans and specifications showing required loading and unloading spaces including the means of ingress and egress and interior circulation shall be submitted to the Township Zoning Administrator for review at the time of application for a Zoning Compliance Permit.

**3.7.2 Off-Road Loading Area Design:**

- a. Each off-road loading or unloading space shall not be less than 10 feet in width or 55 feet in length, with not less than 15 feet in height clearance.
- b. Any loading or unloading space shall not be closer than 50 feet to any other Lot located in any Residential Zoning District unless wholly within a completely enclosed Building/Structure or unless enclosed on all sides by a wall, fence, or compact planting not less than 6 feet in height,
- c. All off-road loading and unloading facilities that make it necessary to back out directly into a public road shall be prohibited.

**3.7.3 Off-Road Loading Area Space Regulations:**

- a. In the case of more than 1 Use on 1 Lot or parcel, the total regulations for off-road loading or unloading facilities shall be the sum of the various Uses computed separately.
- b. All retail sales facilities having over 5,000 square feet of gross floor area shall be provided with at least 1 off-road loading or unloading space, and for every additional 20,000 square feet of gross floor space, or fraction thereof, 1 additional loading or unloading space.
- c. All industrial and wholesale commercial land uses shall provide 1 loading space for each 10,000 square feet of floor space, with a minimum of not less than 2 loading spaces.

**Section 3.8 - ESSENTIAL SERVICES**

Essential services as defined in [Section 6.1.5](#) and as authorized and regulated by law, shall be permitted in all Zoning Districts. It is the intention herein to exempt such services from the application of this Zoning Ordinance.

**Section 3.9 – FLOOD PLAINS**

Notwithstanding any other provisions of this Zoning Ordinance, land subject to periodic flooding shall be used only for Agricultural and Recreational Uses (see [Section 2.5.1](#) and [Section 2.5.6](#)), provided no Buildings/Structures are located within the area subject to flooding.

The location and boundaries of land subject to periodic flooding shall be determined by reference to the U.S. Soil Conservation Service, the U.S. Army Corp of Engineers, or other official authority.

**Section 3.10 – PERFORMANCE STANDARDS**

**3.10.1 Regulations:** No Lot or Building/Structure in any Zoning District shall be used in any manner so as to create any dangerous, injurious, noxious, or otherwise objectionable element or condition so as to adversely affect the surrounding area or adjoining premises. Uses in all Zoning Districts, where permitted, shall comply with the following performance regulations:

- a. **Noise:** Noise which is objectionable due to volume, frequency, or beat shall be muffled or otherwise controlled so that there is no production of sound discernable at Lot lines in excess of the average intensity of road and traffic noise at the Lot lines. Air raid sirens and related apparatus used solely for public purposes are exempt from this requirement.
- b. **Vibration:** No vibration shall be permitted which is discernable without instruments on any adjoining Lot.

- c. **Smoke:** Smoke shall not be emitted with a density greater than No. 1 on the Ringleman Chart as issued by the U.S. Bureau of Mines except for blow-off periods of 10-minute duration of 1 per hour when a density of not more than No. 2 is permitted.
- d. **Odor:** No malodorous gas or matter shall be permitted which is offensive or as to produce a public nuisance or hazard on any adjoining Lot.
- e. **Air Pollution:** No pollution of air by fly-ash, dust, vapors, or other substances shall be permitted which is harmful to health, animals, vegetation, or other Lots, or which can cause excessive soiling.
- f. **Glare:** No direct or reflected glare shall be permitted which is visible from any Lot or from any public road.
- g. **Erosion:** No erosion, by either wind or water, shall be permitted which will carry objectionable substances onto neighboring Lots, lakes, ponds, rivers, or streams.

3.10.2 **Plans:** The application for a Zoning Compliance Permit for a Use subject to performance regulations shall be accompanied by a description of the machinery, process, and products; and specifications for the mechanisms and techniques to be used in meeting the performance standards.

3.10.3 **Enforcement:** The Township Zoning Administrator may refer the application to one or more expert consultants qualified to advise as to whether a proposed Use will conform to the performance standards.

The costs of such services shall be borne by the applicant, and a copy of any report shall be furnished to the applicant and the Township Board of Trustees.

### **Section 3.11 – HOME OCCUPATIONS**

A home occupation shall be clearly incidental and secondary to the Use of the Dwelling Unit for residential purpose. The following additional conditions shall be observed:

- 3.11.1 Such home occupation shall be carried on within the Dwelling or within an Accessory Building/Structure thereto and entirely by the inhabitants thereof.
- 3.11.2 No article shall be sold or offered for sale on the premises except such as is produced within the Dwelling or Accessory Building/Structure or is provided incidental to the service or profession conducted within the Dwelling or Accessory Building/Structure.
- 3.11.3 There shall be no exterior storage of materials or equipment.
- 3.11.4 Not more than 1 person other than the family occupying the Dwelling shall be employed.
- 3.11.5 No nuisances shall be generated by heat, glare, noise, smoke, vibration, noxious fumes, odors, vapors, gases, or matter at any time.

### **Section 3.12 - MEDICAL MARIJUANA**

3.12.1 **Medical Marijuana Caregiver Grow Operations.** The following regulations shall apply to all medical marijuana caregiver grow operations within the Township of Somerset.

- a. An application for a medical marijuana facility Certificate of Occupancy shall be made in writing to the Township Zoning Administrator, who is authorized to create application forms and to receive and process applications and to thereafter grant, deny, suspend,

or revoke said Certificate of Occupancy as set forth in [Section 4.3](#). Applications shall be on forms supplied by and to be filed with the Township Zoning Administrator. Such application shall be signed and dated by the applicant. The application shall contain the following information, plus any other information deemed necessary by the Township Zoning Administrator:

1. The name and any alias used, address, and telephone number of the applicant;
2. The location of the medical marijuana facility and a brief description of the amount of marijuana to be distributed, or number of plants to be grown on the premises, if any;
3. Caregiver must disclose only the date of birth of the qualifying patient, the date of issuance and expiration date of the medical marijuana registry identification card and the random identification number assigned to each qualified patient;
4. The applicant's criminal record, if any;
5. An authorization for the Township Zoning Administrator and/or the Township Police Department to carry out a background investigation on the applicant;
6. If the applicant is not the owner of the proposed location of the medical marijuana caregiver grow operation a notarized statement from the owner of the property authorizing submission of the application;
7. An acknowledgment by the applicant that applicant, as well as the applicant's qualifying patients, may be subject to prosecution under United States laws relating to the possession and distribution of controlled substances, and that Township of Somerset accepts no legal liability in connection with the approval and operation of the medical marijuana caregiver grow operation; and
8. A statement that the information provided is true and accurate and that, if a Certificate of Occupancy is granted, the applicant will abide by all applicable Ordinances and Statutes.

The names and other identifying information of any qualifying patient or registered primary caregiver gathered for the purposes of this Section 3.12 shall be exempt from disclosure pursuant to the Michigan Medical Marijuana Act (Initiated Law 1 of 2008, [MCL 333.26421 et. seq.](#)).

- b. All Certificates of Occupancy are subject to the following conditions, which shall be noted on the application form:
  1. The applicant shall permit inspection of the premises and/or activity at reasonable times by any authorized representative of the Township of Somerset;
  2. The applicant shall not operate a medical marijuana facility at any time after the Certificate of Occupancy is suspended or revoked; and
  3. No Certificate of Occupancy shall be issued unless and until the applicant, if deemed necessary by the Township of Somerset Police Department, submits to being fingerprinted and photographed as part of the background investigation.
- c. Any person who has been under any sentence, including parole, probation, or actual incarceration, for the commission of a felony within 5 years preceding the date of application shall be disqualified from receiving a Certificate of Occupancy to operate a medical marijuana caregiver grow operation.

- d. The Township Zoning Administrator shall issue a Certificate of Occupancy to the applicant if the Township Zoning Administrator is satisfied that the applicant has met the regulations of this Article III and all applicable State of Michigan statutes and County of Hillsdale and Township of Somerset Ordinances, and the applicant has paid the Certificate of Occupancy fee.
- e. A Certificate of Occupancy issued pursuant to this Article III does not eliminate the need for the applicant to obtain other licenses and permits (i.e., building, mechanical, electrical, plumbing, water and sewer, etc.) required for the operation of a medical marijuana facility. The pertinent inspector must provide a report confirming that all lights, plumbing, equipment, and all other means proposed to be used to cultivate marijuana plants are in accordance with applicable code(s).
- f. Medical marijuana caregiver grow operation shall not be permitted as home occupation (see [Section 3.11](#)).
- g. No medical marijuana caregiver grow operation may operate in close proximity to sites where children are regularly present or in a Residential Zoning District. Such operations must adhere to the following minimum distances:
  - 1. More than 1,000 feet from a daycare facility (see Sec. Section 102 of PA 110 of 2006, [MCL 125.3102](#));
  - 2. More than 1,000 feet from a religious institution;
  - 3. More than 1,000 feet from a public park, community center, library, or the Township Hall;
  - 4. More than 1,000 feet from a public or private preschool, elementary school, high school, community college (recognizing drug-free school zones), including all other schools that have different name references but serve students of the same age;
  - 5. More than 1,000 feet from an adult use as defined by this Zoning Ordinance;
  - 6. More than 1,000 feet of another medical marijuana grow facility or a medical marijuana home use; and
  - 7. More than 1,000 feet of a Residential Zoning District.
- h. The primary caregiver may cultivate up to 60 marijuana plants provided that no more than 12 marijuana plants are cultivated per qualifying patient, not including the primary caregiver. The primary caregiver may cultivate up to 12 additional marijuana plants if the primary caregiver is also a qualifying patient. The plants maintained for each qualifying patient must be kept in a separate locked facility, as defined by the Michigan Medical Marijuana Act (Initiated Law 1 of 2008, [MML 333.26421 et. seq.](#)), and accessible only to the primary caregiver and the qualifying patient.
- i. The primary caregiver may possess up to 12½ ounces of marijuana provided that not more than 2½ ounces are possessed per qualifying patient, not including the primary caregiver. The primary caregiver may possess up to 2½ ounces of additional marijuana if the primary caregiver is also a qualifying patient. An incidental amount of seeds, stalks, and roots may also be retained by the primary caregiver.
- j. Consumption or use of medical marijuana shall not be permitted on the site of a medical marijuana caregiver grow operation.
- k. No person under the age of 18 shall be permitted on the site of the medical marijuana caregiver grow operation unless the person is a registered qualifying patient.
- l. A medical marijuana caregiver grow operation shall not be permitted to have drive-through facilities.



- m. The operator of a medical marijuana caregiver grow operation shall keep a written record in English, on a form available from the Township of Somerset, of all marijuana located on the premises and of all marijuana or marijuana products distributed and such other information designated on the form. Copies of registry cards for all current qualifying patients and the primary caregiver must be maintained with this record.
- n. There is no authorization for marijuana-related stores, dispensaries, cooperatives, or other businesses that do not meet the regulations set by this Section 3.12 for a medical marijuana caregiver grow facility or medical marijuana home use and may not market to a wide customer base (see [Michigan Attorney General Opinion No. 7259](#).)

3.12.2 **Medical Marijuana Home Uses:** The following regulations shall apply to all medical marijuana home uses within the Township of Somerset.

- a. No person may engage in the activities of a primary caregiver in a Residential Zoning District unless a qualifying patient also resides in the home. The primary caregiver may only grow plants for use by the qualifying patient and the primary caregiver if the primary caregiver is also a qualifying patient.
- b. A person engaging in the activities of a primary caregiver in a Residential Zoning District may only grow marijuana plants in the primary caregiver's residence.
- c. No more than 24 marijuana plants may be grown in a medical marijuana home use, this number being 12 plants for a registered qualifying patient, not including the primary caregiver, plus 12 plants if the primary caregiver is also a registered qualifying patient. The plants maintained for each qualifying patient must be kept in a separate locked facility, as defined by the Michigan Medical Marijuana Act, and accessible only to the primary caregiver and the qualifying patient.
- d. A primary caregiver, on behalf of a qualifying patient with whom the primary caregiver resides, may possess an amount of medical marijuana that does not exceed 2½ ounces of usable marijuana (and an additional 2½ ounces if the primary caregiver is also a qualifying patient), plus an incidental amount of seeds, stalks, and roots.
- e. The use of the Dwelling Unit as a medical marijuana home use must be clearly incidental and subordinate to its use for residential purposes and no more than 20% of the gross floor area of the Dwelling may be used in any way for the medical marijuana home use.
- f. No change may occur to the outside appearance of the Dwelling and no signs may be posted on the Dwelling or Lot advertising the medical marijuana home use.
- g. Equipment not normally used for purely domestic or household purposes or any portion of the Dwelling where energy use and heat generation resulting from the growth of marijuana exceeds levels reasonably attributable to residential uses are permitted if the Township Zoning Administrator, or the Township Zoning Administrator's designee, approves such use. The Township Zoning Administrator must approve of such use if the Township Zoning Administrator is satisfied that the intensity of use will not be increased to a level that will adversely impact any Lot within 300 feet of the Dwelling and that any energy use and heat generation resulting from the growth of marijuana exceeding levels reasonably attributable to residential uses has been approved by the Township Fire Chief and the Township Zoning Administrator.

- h. No activity related to the medical marijuana home use occurring on the premises may adversely impact the surrounding neighborhood or the right of surrounding residents to quiet enjoyment of their property, including but not limited to, the creation of noise, vibrations, odors, heat, glare, unnatural light, or electrical interference detectable beyond the property line.
- i. Storage and manufacture of medical marijuana shall only be permitted inside of an enclosed, locked facility such as a closet, room or other closed area equipped with locks or other security devices that only permit access by the qualifying patient or registered primary caregiver.
- j. Qualifying patients, and their primary caregivers, may be subject to prosecution under United States laws relating to the possession and distribution of controlled substances, and Township of Somerset accepts no legal liability in connection with the approval and operation of the medical marijuana home use; and
- k. There is no authorization for marijuana-related stores, dispensaries, cooperatives, or other businesses that do not meet the regulations set by this Section 3.12 for a medical marijuana home use or medical marijuana caregiver grow operation and may not market to a wide customer base (see [Michigan Attorney General Opinion No. 7259](#)).

**Section 3.13 – STORAGE OF MATERIALS**

The location or storage of abandoned, discarded, unused, unusable, or inoperative vehicles, appliances, furniture, equipment, or material shall be regulated as follows:

- 3.13.1 On any Lot in any Agricultural Zoning District, Residential Zoning District, or Commercial Zoning District, the owner or tenant, but not for hire or for business, shall locate and store such materials within a completely enclosed Building/Structure.
- 3.13.2 On any Lot in any Industrial Zoning District, the owner or tenant, whether or not for hire or for business, shall locate and store such materials within a completely enclosed Building/Structure or within an area surrounded by a solid, unpierced fence or wall at least 7 feet in height and not less in height than the materials located or stored therein, and not closer to the Lot lines than the minimum yard regulations for Buildings/Structures permitted in said Zoning Districts.
- 3.13.3 Nothing in this Zoning Ordinance shall permit the storage or parking of any vehicle or non-permanent Building/Structure within the required front yard of any Lot within a Residential Zoning District, except that the parking of a vehicle on a driveway located on private property shall not be prohibited.

**Section 3.14 – MOBILE HOMES AND TRAVEL TRAILERS**

- 3.14.1 No mobile home shall be used other than as a 1-Family Dwelling and in a duly licensed Mobile Home Park or in a Mobile Home Subdivision, except a mobile home may be used as a temporary field office provided it is certified as such by the Township Zoning Administrator.
- 3.14.2 The Township Zoning Administrator shall have authority to grant a permit for temporary occupancy of mobile homes on any Lot in a Residential Zoning District subject to the following conditions:
  - a. During the period of construction of a new permanent Dwelling, but not to exceed a period of 12 consecutive months, the owner of such permanent Dwelling premises, and members of such owner’s residence, shall be permitted to occupy as a temporary residence



one mobile home situated at such construction site provided that such owner intends to occupy as a residence such Dwelling upon completion of its construction.

- b. Such mobile home shall not be located between the established setback line and the public right-of-way line of such premises.
- c. The mobile home shall contain sleeping accommodations, a flush toilet, and a tub or shower bath adequate to serve the occupants thereof.
- d. The sanitary facilities of the mobile home for the disposal of sewage and waste shall be properly connected to the central sewerage system available at such premises and in case such system is not there available, then properly connected to the existing septic tank sewage disposal system which is approved by the Hillsdale County Health Department for the permanent Dwelling to be constructed thereat.

3.14.3 No travel trailer shall be used as a Dwelling except for a period not to exceed 2 weeks and in a duly licensed travel trailer park, or as a temporary Dwelling for a period not to exceed one week provided such travel trailer is situated on a parcel of land upon which is located a Dwelling with water and sanitary facilities accessible to the travel trailer occupants and certified by the Township Zoning Administrator.

### **Section 3.15 – FENCES**

Fences in all Residential Zoning Districts are subject to the following condition: Fences which enclose property shall not exceed 6 feet in height, measured from the surface of the ground in the rear and side yards, and shall not exceed 3 feet in height, measured from the surface of ground in the front yard.

### **Section 3.16 – TEMPORARY OR SEASONAL USES**

Circuses, carnivals, flea markets, organized special events or other transient enterprises may be permitted in any Zoning District, under written recommendation of the Township Zoning Administrator and approval of the Township Board of Trustees subject to the following:

- 3.16.1 The applicant for this Use or event shall submit to the Township Zoning Administrator a preliminary Site Plan, and in writing, describe in detail the event or Use, its duration, proposed traffic flow, how refuse and sanitation will be handled, how required parking will be accomplished and identify any nuisances or public safety issues this Use or event may create and how they will be mitigated.
- 3.16.2 If the Township Board of Trustees determines, as part of its review and terms and conditions for approval, that the Use or event will require the assistance of the Township Police or Fire Department, or any other Township services, the applicant accepts responsibility for all appropriate charges as determined by the Township of Somerset.
- 3.16.3 In the interest of insuring compliance with the Zoning Ordinance provisions, protection of natural resources and the health, safety, and welfare of the public, payment for Township of Somerset facilities and assistance, and return to the site's original condition, the applicant may be required to deposit a performance guarantee in the amount and terms as reasonably determined by the Township Board of Trustees.

### **Section 3.17 - COMMUNICATION TOWERS**

3.17.1 The following Site and Developmental Regulations shall apply:

- a. A minimum site of 1 acre and 200 feet of road frontage shall be required.
- b. The appropriateness of guy wire shall be considered when the property abuts Residential Zoning District or Use.
- c. The base of the communication tower and the guy wire supports shall be fenced with a minimum of 6-foot-high fence.

3.17.2 The following Special Performance Standards shall apply:

- a. Communication towers must be set back from all property lines a distance equal to its height.
- b. Accessory Buildings/Structures are limited to Uses associated with the operation of the communication tower and may not be located any closer to any property line than the minimum front yard regulation of the appropriate Zoning District as found in [Section 2.6](#) (Zoning District Area, Yard, Height, and Bulk Regulations).
- c. Accessory Buildings/Structures shall not exceed 600 square feet of gross building area.
- d. All communication towers shall be equipped with an anti-climbing device to prevent unauthorized access.
- e. The plans of the communication tower shall be certified by a registered structural engineer.
- f. The applicant shall provide verification that the antenna mount and Structure have been reviewed and approved by a professional engineer and that the installation is in compliance with all applicable codes.
- g. All communication towers must meet the standards of the Federal Communications Commission and the Federal Aviation Administration
- h. Communication towers in excess of 100 feet in height above grade level shall be prohibited within a 2-mile radius of a public airport or ½ mile of a helipad.
- i. No part of any communication tower or antenna shall be constructed, located, or maintained at any time, permanently or temporarily, on or upon any required setback area for the Zoning District on which the antenna or communication tower is to be located. In no case shall a communication tower or antenna be located within 30 feet of a property line.
- j. Metal communication towers shall be constructed of, or treated with, corrosive-resistant material.
- k. Antennas and metal communication towers shall be grounded for protection against a direct strike by lightning and shall comply as to electric wiring and connection with all applicable State of Michigan Statutes and County of Hillsdale and Township of Somerset Ordinances, regulations and standards.
- l. Communication towers with antennas shall be designed to withstand a uniform wind loading.
- m. All signals and remote control conductors of low energy extending substantially horizontally above the ground between a communication tower or antenna and a Building/Structure, or between communication towers, shall be at least 8 feet above the ground at all points, unless buried underground.
- n. Communication towers shall be located so that they do not interfere with reception in nearby residential areas.
- o. Communication towers shall be located so that there is room for vehicles doing maintenance to maneuver on the property of the owner and/or leased by the applicant.

- p. The base of the communication tower shall occupy on more than 500 square feet.
- q. Minimum space between communication tower locations shall be 1 mile in order to prevent a concentration of communication towers in one area.
- r. Height of the communication tower shall not exceed 200 feet from the grade within a Commercial Zoning District, and 300 feet from grade within an Industrial Zoning District or Agricultural Zoning District.
- s. Communication towers shall not be artificially lightened except as required by the Federal Aviation Administration.
- t. Existing on-site vegetation shall be preserved to the maximum extent practicable.
- u. There shall not be displayed advertising or identification of any kind intended to be visible from the ground or other Buildings/Structures, except as required for emergency purposes.
- v. There shall be no employees located on the site on a permanent basis to service or maintain the communication tower. Occasional or temporary repair and service activities are excluded from this restriction.
- w. Where the property adjoins any Residential Zoning District or Use, the developer shall plant 2 alternating rows of evergreen trees with a minimum height of 5 feet on 20 foot centers along the entire perimeter of the communication tower and related Buildings/Structures. In no case shall the evergreens be any nearer than 10 feet to any Building/Structure.
- x. The policy of the community is to minimize the number of communication towers in the Township of Somerset. Therefore, the Township of Somerset shall require the colocation of communication towers. Pursuant to this policy, the following standards apply to the communication towers:
  - 1. All new and modified communication towers shall be designed and constructed so as to accommodate colocation.
  - 2. A Conditional Use Permit for the construction and Use of a new communication tower shall not be granted unless and until the applicant demonstrates that a feasible colocation is not available for the coverage area and capacity needs.
  - 3. The following information shall be submitted prior to Township of Somerset approval to construct a communication tower:
    - (a) Site Plan in accordance with [Section 4.8](#).
    - (b) A maintenance plan, and any applicable maintenance agreement, shall be presented and approved as part of the Site Plan for the proposed communication tower. Such plan shall be designed to ensure the long-term, continuous maintenance to a reasonable prudent standard.
    - (c) The application shall include a description of security to be posted at the time of receiving a building permit for the communication tower to ensure removal of the facility when it has been abandoned or is no longer needed. In this regard, the Township Planning Commission shall specify the form of security as approved by the Township Attorney and recorded at the office at the County Registrar of Deeds, establishing a promise of the applicant and owner of the property to remove the facility in a timely manner as required under this Section 3.17, with the further provision that the applicant and owner shall be responsible for the payment of any cost and attorney's fees incurred by the community in securing removal. The

security shall be adjusted on an annual basis according to the U.S. Bureau of Labor Statistic's Consumer Price Index annual average for United States cities in the North Central Region of the United States.

- (d) The name, address, and phone number of the person to contact for engineering, maintenance and other notices purposes. This information shall be continuously updated during all times the communication tower is on the premises.

### **Section 3.18 – Outdoor Wood Furnaces**

- 3.18.1 **Purpose:** The purpose of this Section 3.18 is to protect the public health, safety and welfare by prohibiting certain outdoor furnaces and by requiring that all outdoor furnace systems are properly installed and maintained consistent with this Zoning Ordinance and the manufacturer's instructions.
- 3.18.2 **Definitions:** See [Section 6.1.15](#) for a definition of Outdoor Wood Furnaces and associated terms.
- 3.18.3 This Zoning Ordinance shall apply to Outdoor Wood Furnaces which are installed, or thereafter replaced or substituted after the effective date of this amendment.
- a. No person shall construct, install, establish, operate or maintain an Outdoor Wood Furnace except as permitted under this Zoning Ordinance and in compliance with the manufacturer's specifications. If there is a conflict between the manufacturer's specifications and this Zoning Ordinance the more restrictive shall apply.
  - b. Only EPA (U.S. Environmental Protection Agency) OWHH (Outdoor Wood-fired Hydronic Heaters) Phase 1 Program qualified models are permitted.
  - c. The Outdoor Wood Furnace must be installed and maintained in accordance with the manufacturer's standards and specifications.
  - d. The burning of rubbish, garbage, plastic materials, foam or synthetics, newspaper, cardboard, or any other material not within the definition of Natural Wood is prohibited.
  - e. The Outdoor Wood Furnace must be set back no less than 125 feet from adjacent property boundaries.
  - f. The Outdoor Wood Furnace shall be at least 40 feet from the residence it serves.
  - g. The Outdoor Wood Furnace shall not be located in the front yard of the property.
  - h. The Outdoor Wood Furnace shall have a sufficient buffer established to deter fire.
  - i. The Outdoor Wood Furnace shall not be installed on a parcel of land less than 5 acres.
- 3.18.4 Application of Zoning Ordinance to Outdoor Wood Furnaces which were installed prior to the effective date of this amendment.
- a. Such Outdoor Wood Furnaces must be operated and maintained in compliance with the manufacturer's specifications. If there is a conflict between the manufacturer's specifications and this Zoning Ordinance the more restrictive shall apply.
  - b. Section 3.18.3.d and Section 3.18.3.h shall apply.
  - c. Section 3.18 shall apply for any replacement or substitution of such Outdoor Wood furnace.

- d. Should the Township Zoning Administrator, after due investigation, determine the Outdoor Wood furnace to be a verifiable nuisance or if verifiably interfering with the health, safety and welfare of the adjacent property owners or occupants, the Use of such Outdoor Wood Furnace shall cease.

3.18.5 **Permit Approval Procedure:** Prior to installation of an Outdoor Wood Furnace covered by Section 3.18.3. or a replacement of an Outdoor Wood Furnace covered by Section 3.18.4. a Zoning Compliance Permit must be obtained and a permit fee paid as may be established by the Township Board of Trustees. Application for a permit must be by written request which shall include a copy of the owner's manual and installation instructions of the proposed Outdoor Wood Furnace. A drawing to scale showing the existing boundary lines and proposed location of the Outdoor Wood Furnace shall demonstrate the proposed Outdoor Wood Furnace shall be installed in compliance with Section 3.18. The Township Zoning Administrator shall grant a Zoning Compliance Permit if it is determined that the proposed Outdoor Wood Furnace complies with this Zoning Ordinance and the manufacturer's specifications.

*This page is intentionally blank.*

## **Article IV**

### **ADMINISTRATION AND AMENDMENT OF THE ZONING ORDINANCE**

#### **Section 4.1 – ADMINISTRATION OF THE ZONING ORDINANCE**

- 4.1.1 **Purpose:** It is the purpose of this Article IV to provide the procedures for the administration of this Zoning Ordinance, issuance of permits, inspection of properties, collection of fees, handling of violators, and enforcement of the provisions of this Zoning Ordinance and amendments thereto.
- 4.1.2 **Administration:** Except when herein otherwise stated the provisions of this Zoning Ordinance shall be administered by the Township Zoning Administrator or by such deputies of the Zoning Administrator's department as the Township Board of Trustees may designate to enforce the provisions of this Zoning Ordinance.
- 4.1.3 **Duties of the Township Zoning Administrator:** The Township Zoning Administrator shall have the power to grant Zoning Compliance Permits and Certificates of Occupancy and to make inspections of Buildings/Structures or premises necessary to carry out Township Zoning Administrator duties in the enforcement of this Zoning Ordinance. It shall be unlawful for the Township Zoning Administrator to approve plans or issue any permits or Certificates of Occupancy for any excavation or construction until he has inspected such plans in detail and found them to conform with this Zoning Ordinance, nor shall the Township Zoning Administrator vary or change any terms of this Zoning Ordinance.

If the Township Zoning Administrator shall find that any of the provisions of this Zoning Ordinance are being violated, the Zoning Administrator shall notify, in writing, the person responsible for such violation, indicating the nature of the violation and ordering the action necessary to correct it. The Zoning Administrator shall order discontinuance of illegal use of any Lot or Buildings/Structures; removal of illegal Buildings/Structures, or of illegal additions, alterations, or structural changes; discontinuance of any illegal work being done; and shall take any other action authorized by this Zoning Ordinance to ensure compliance with or to prevent violation of its provisions.

The Township Zoning Administrator shall submit to the Township Planning Commission and the Township Board of Trustees quarterly reports fully explaining the type and nature of Permitted Uses; the nature and extent of violations of this Zoning Ordinance; and the type and nature of Nonconforming Uses and Buildings/Structures. The Township Zoning Administrator shall maintain a record of all Zoning Compliance Permits and Certificates of Occupancy.

#### **Section 4.2 – ZONING COMPLIANCE PERMITS**

- 4.2.1 **Issuance of Zoning Compliance Permits:** No Building/Structure, or part thereof, shall hereafter be located, erected, constructed, reconstructed, altered, converted, or enlarged or moved; nor shall any change be made in the Use of any Building/Structure and/or land without a Zoning Compliance Permit having been obtained from the Township Zoning Administrator for Building/Structure or land. A Zoning Compliance Permit application shall be filled out and submitted to the Township Zoning Administrator.

The Township Zoning Administrator shall require that all applications for Zoning Compliance Permits shall be accompanied by plans and specifications including a plot plan in duplicate, drawn to scale, showing the following information.

- a. The actual dimensions and shape of the Lot to be built upon; and,
- b. The exact size and location of existing Buildings/Structures on the Lot, if any; and
- c. The location and dimensions of the proposed Building/Structure or alteration.

1 copy of the plan shall be returned to the applicant by the Township Zoning Administrator after such copy has been approved or disapproved, and attested to same by the Township Zoning Administrator's signature on such copy. The Township Zoning Administrator shall retain the original copy, similarly marked, for the Township Zoning Administrator's files. Whenever the Buildings/Structures, and Uses as set forth in the application are in conformity with the provisions of this Zoning Ordinance, the Township Zoning Administrator shall issue the applicant a Zoning Compliance Permit within 10 days of the filing thereof. Where action of the Township Zoning Board of Appeals or the Township Planning Commission is required in any case, as set forth in this Zoning Ordinance, the Township Zoning Administrator shall issue such permit promptly following such action.

- 4.2.2 **Voiding of Zoning Compliance Permit:** Any Zoning Compliance Permit granted under this Zoning Ordinance shall become null and void and fees forfeited unless construction and/or Use completed within 545 days of the date of issuance. A Zoning Compliance Permit shall be renewable upon reapplication and upon payment of the fee, subject however, to the provisions of the Zoning Ordinance in effect at the time of renewal.

#### **Section 4.3 – CERTIFICATE OF OCCUPANCY, FINAL INSPECTION**

- 4.3.1 **Issuance of Certificate of Occupancy:** No Building/Structure, or part thereof, shall be occupied by or for any Use for which a Zoning Compliance Permit is required by this Zoning Ordinance unless and until a Certificate of Occupancy shall have been issued for such Use. The holder of a Zoning Compliance Permit for the construction, erection, or moving of any Building/Structure or part thereof, for the establishment of a Use, shall make application to the Township Zoning Administrator immediately upon the completion of the work authorized by the Zoning Compliance Permit for a final inspection.

A Certificate of Occupancy shall be issued by the Township Zoning Administrator within 5 days after receipt of such application if it is found that the Building/Structure, or part thereof, is in accordance with the provisions of this Zoning Ordinance.

- 4.3.2 **Voiding of Certificate of Occupancy:** Any Certificate of Occupancy granted under this Zoning Ordinance shall become null and void if such Building/Structure or Use for which said Certificate of Occupancy was issued are found by the Township Zoning Administrator to be in violation of this Zoning Ordinance. The Township Zoning Administrator upon finding such violation shall immediately notify the Township Board of Trustees of said violation and void the Certificate of Occupancy.

#### **Section 4.4 – FEES AND CHARGES**

The Township Board of Trustees shall establish a schedule of fees, charges, and a collection procedure for Zoning Compliance Permits, Certificates of Occupancy, appeals and other matters pertaining to the Zoning Ordinance. The schedule of fees shall be posted in the office of the Township Zoning Administrator, and may be altered or amended only by the Township Board of Trustees. No permit, certificate, Conditional Use on approval, or variance shall be issued unless or until such costs, charges, fees, or expenses listed in this Zoning Ordinance have been paid in full,



nor shall any action be taken on proceedings before the Township Zoning Board of Appeals, unless or until preliminary charges and fees have been paid in full.

#### **Section 4.5 – ENFORCEMENT**

- 4.5.1 **Enforcement:** The Township Board of Trustees may instruct the Township Zoning Administrator or the Township Attorney to initiate a civil or criminal complaint or other legal action to enforce the Zoning Ordinance. Although the default violation is a civil infraction (Section 4.5.2), the Township of Somerset may choose enforcement through a charge for knowing and intention violations (Section 4.5.3), or seek injunctive relief for substantive serious or threatening violations (Section 4.5.4). However, enforcement options shall not be mixed for example with the same violation being charged as a misdemeanor and a civil infraction. The Township Zoning Administrator is authorized to issue civil infraction citations under this Section 4.5.
- 4.5.2 **Civil Action Violation:** Unless otherwise specified in the Zoning Ordinance, violations of the Zoning Ordinance are civil infractions, including without limitation, fines, damages, expenses and costs as authorized by the Revised Judicature Act of 1961 (PA 236 of 1961, [MCL 600.101 et. seq.](#)) as amended, subject to the following:
- a. Civil infraction sanctions include a civil fine not less than \$75 plus costs, damages, expenses and other sanctions for each infraction.
  - b. An initial repeated civil infraction may lead to increased civil fine not less than \$250 plus costs, damages, expenses and other sanctions. Subsequent repeated civil infraction(s) may lead to increased civil fine not less than \$500 plus costs, damages, expenses and other sanctions.
  - c. A civil infraction action may be commenced upon the issuance of a civil infraction citation which directs the alleged violator to appear in court.
  - d. Should the civil infraction requiring the alleged violator to appear in court not be complied with, this is a violation punishable by a fine not more than \$500 with additional costs, or imprisonment for a term not to exceed 90 days, or both fine (with additional costs) and imprisonment.
  - e. Failure to comply with a court order, judgment or default in payment of a civil fine and/or additional costs as ordered may result in enforcement actions, including, but not limited to, imprisonment, collections, liens or other remedies as permitted in Chapter 87 of PA 236 ([MCL 600.8701 et. seq.](#)) as amended.
  - f. Within context of the Zoning Ordinance, a municipal civil infraction is not a 'crime' or a lesser included offense of a criminal offense, or an Ordinance violation which is not a civil infraction.
- 4.5.3 **Violation:** A violation is punishable upon conviction by a fine not more than \$500 with additional costs, or imprisonment for a term not to exceed 90 days, or both fine (with additional costs) and imprisonment.

A Violation includes: (a) a knowing false statement, representation or certification in an application, report, record, plan or other document filed or required to be maintained pursuant to the Zoning Ordinance, or (b) a willful continuation of violating the Zoning Ordinance after suspension or revocation of a permit authorized under this Zoning Ordinance, other Ordinances or State law.

- 4.5.4 **Nuisance Per Se and Injunctive Relief:** A violation of any Ordinance contained in this Zoning Ordinance which is determined to be detrimental to the health, safety and general welfare of the residents, property owners and other persons/entities within the Township of Somerset and deemed a public nuisance per se. In addition to any other relief or penalty provided by the Zoning Ordinance or allowed by law, such violation constitutes a basis for injunctive relief sought by the Township of Somerset and/or any owner(s) of real estate within the Township of Somerset against the violator and/or land owner to restrain and prohibit the violator and/or land owner from continuing the violation.
- 4.5.5 **Continuing Offense:** Each day a violation continues may be determined as a separate or repeat offense subject to penalties or sanctions as such.
- 4.5.6 **Land Division Violation:** No zoning permit shall be issuable in event of violation of Michigan's Land Division Act (PA 288 of 1967, [MCL 560.101 et. seq.](#)), as amended.
- 4.5.7 **Building/Structure Construction Violation:** An approved Zoning Compliance Permit is required to perform any construction and/or seek to receive a building permit as required by the Township of Somerset or other permits enforced by the Township of Somerset.
- 4.5.8 **Overlapping Jurisdiction:** Prior to the issuance of any Zoning Compliance Permit, the Township Zoning Administrator must reasonably determine such permit has been or will be approved by any United States, State of Michigan, County of Hillsdale, and/or Township of Somerset agencies which have jurisdiction in such matters.
- 4.5.9 **Administrative Liability:** No officer, member, agent or employee of the Township of Somerset shall be personally liable for any damage or consequence which may take place as a result of any act, decision, or other event or cause by discharging duties and responsibilities pursuant to the Zoning Ordinance.

#### **Section 4.6 – PUBLIC HEARING NOTICE REGULATIONS**

All applications for a variance to the Township Zoning Board of Appeals and for amendments and Conditional Uses to the Township Planning Commission shall be processed and the required public hearing shall be noticed and conducted in compliance with Section 103 and Section 203 of the Michigan Zoning Enabling Act (PA 110 of 2006, [MCL 125.3103](#) and [MCL 125.3203](#)).

#### **Section 4.7 – NONCONFORMITIES**

Where within the Zoning Districts established by this Zoning Ordinance, or by amendments, there exists Lots, Buildings/Structures, and Uses of land and Buildings/Structures which were lawful before this Zoning Ordinance was adopted or amended and which would be prohibited, regulated, or restricted under the terms of this Zoning Ordinance, or future amendment; it is the intent of this Zoning Ordinance to permit such Lots, Buildings/Structures, and Uses of land and Buildings/Structures to remain until they are discontinued or removed. It is further the intent of this Zoning Ordinance that such nonconformities shall not be enlarged, expanded, or extended except as provided herein; nor to be used as ground for adding other Lots, Buildings/Structures or Uses prohibited elsewhere in the same Zoning District.

- 4.7.1 **Nonconforming Uses of Land:** Where, on the date of adoption or amendment of this Zoning Ordinance, a lawful Use of land exists that is no longer permissible under the provisions of this Zoning Ordinance, such Use may be continued as long as it remains otherwise lawful, subject to the following provisions:
- a. No such Nonconforming Use of land shall be enlarged, expanded, or extended to occupy a greater area of land than was occupied on the effective date of adoption or amendment of this Zoning Ordinance; and no Accessory Building/Structure or Use shall be established therewith.
  - b. No such Nonconforming Use of land shall be moved in whole or in part to any other portion of such land not occupied on the effective date or adoption or amendment of this Zoning Ordinance.
  - c. If such Nonconforming Use of land ceases for any reason for a period of more than 180 consecutive days, the subsequent Use of such land shall conform to the regulations and provisions set by this Zoning Ordinance for the Zoning District in which such land is located.
- 4.7.2 **Nonconforming Buildings/Structures:** Where, on the effective date of adoption or amendment of this Zoning Ordinance, a lawful Building/Structure exists that could not be built under the regulations of this Zoning Ordinance by reason of restrictions upon Lot area, Lot width, Lot coverage, height, open land, or other characteristics of such Building/Structure or its location upon a Lot, such Building/Structure may be continued so long as it remains otherwise lawful subject to the following provisions.
- a. No such Building/Structure shall be enlarged, expanded, extended, or altered in a way which increases its nonconformance.
  - b. Should any such Building/Structure be destroyed by any means to an extent of more than 50% of its replacement cost at the time of destruction, it shall not be reconstructed except in conformity with the provisions of this Zoning Ordinance.
  - c. Should any such Building/Structure be moved for any reason, of any distance, it shall thereafter conform to the regulations of the Zoning District in which it is located after it is moved.
- 4.7.3 **Nonconforming Uses of Buildings/Structures:** Where, on the date of adoption or amendment of this Zoning Ordinance, a lawful Use of a Building/Structure exists that is no longer permissible under the regulations of this Zoning Ordinance, such Use may be continued so long as it remains otherwise lawful subject to the following provisions.
- a. No Nonconforming Use of a Building/Structure shall be enlarged, expanded, extended, or altered except in changing the Use of such Building/Structure to a Permitted Use in the Zoning District in which such Building/Structure is located.
  - b. When a Nonconforming Use of a Building/Structure is discontinued or abandoned for more than 180 consecutive days, the Building/Structure shall not thereafter be used except in conformance with the regulations of the Zoning District in which it is located.
  - c. Any Building/Structure devoted in whole or in part to any Nonconforming Use, work may be done in any period of 12 consecutive months on ordinary repairs or on repairs or replacement of non-bearing walls, fixtures, wiring or plumbing to an extent not to exceed 10% of the then current replacement value, of the Building/Structure, provided that the volume of such Building/Structure or the number of families housed therein as it existed on the date of adoption or amendment of this Zoning Ordinance shall be deemed

to prevent the strengthening or part thereof declared to be unsafe by any official charged with protecting the public safety upon order of such official.

- d. Should any Building/Structure containing a Nonconforming Use be moved, for any reason of any distance, it should thereafter conform to the regulations of the Zoning District in which it is located after it is moved.
- e. Should any Building/Structure devoted in whole or in part to any Nonconforming Use be destroyed by any means to an extent of more than 50% of its replacement cost at the time of destruction, it shall not be reconstructed nor be devoted to any Use except in conformity with the regulations of the Zoning District in which it is located.

4.7.4 **Change of Tenancy or Ownership:** There may be a change of tenancy, ownership, or management of an existing Nonconforming Use or Building/Structure; provided there is no change in the nature or character of such Nonconforming Use or Building/Structure.

4.7.5 **Nonconforming Lots of Record:** In any Zoning District in which a 1-Family Dwelling is permitted, notwithstanding limitations imposed by other provisions of this Zoning Ordinance, a 1-Family Dwelling may be erected on any single Lot of record at the effective date of adoption or amendment of this Zoning Ordinance, regardless of its area or width, provided that the owner of such Lot does not own any adjoining property; and further provided, however that no Lot shall be less than 40 feet wide; the minimum side yard shall be 10% of the Lot width or 6 feet, whichever is greater; the depth of the rear yard shall not be less than 25 feet; the depth of the front yard shall not be less than 25 feet; and all regulations of the Hillsdale County Health Department shall be met before construction is begun. Any variance of yard regulations from the above provisions shall be obtained only through action of the Township Zoning Board of Appeals.

Any existing platted subdivision Lot of record abutting a body of water shall require a rear setback of not less 25 feet. The rear setback is the distance between the Building/Structure and the body of water.

4.7.6 **Extension and Substitution:** There shall be a specific exemption from the preceding prohibitions, whether in Section 4.7 or any other Section of Article IV, against rebuilding, altering, replacing, improving, enlarging, extending, substituting or modifying a Nonconforming Use when such Use is occupied as a Dwelling. In this case, the owner or tenant of said Dwelling shall make application to the Township Zoning Board of Appeals requesting an exemption from the aforesaid prohibitions. If the Township Zoning Board of Appeals, after a hearing upon such application, shall determine that for reasons of health, sanitation, safety or the well-being of the occupants that the request is proper, then the Township Zoning Board of Appeals may authorize the tenant to rebuild, alter, replace, improve, enlarge, extend, substitute or modify said Dwelling. Prior to granting any such request under this Section 4.7, the Township Zoning Board of Appeals specifically shall make the following findings of fact and apply the following standards:

- a. That the Use was originally constructed as a Dwelling, and has continuously been occupied as a Dwelling.
- b. That the Use currently is occupied as a Dwelling by the owner, or, if not occupied by the owner, then the premises shall not be leased or rented for monetary gain.
- c. That by reason of original construction, current condition, or as part of the proposed changes, the Use will have electrical and sanitation facilities meeting the regulations of this Zoning Ordinance and any applicable building codes.

- d. That by reason of original construction, current condition, or proposed change, the Use will meet the building code regulations set forth by this Zoning Ordinance and any building code applicable to the type of Use and type of Zoning District.
- e. That the Use adequately is serviced by public utilities and private or public roads.
- f. That the proposed changes will materially and substantially benefit the Use as a Dwelling place and/or make the Use more in conformity with the provisions of this Zoning Ordinance and any building code.
- g. That the proposed changes will not have an adverse effect upon the Uses in the general vicinity by creating new or different violations of this Zoning Ordinance.

Proceedings under this Section 4.7 shall follow the same procedure and be subject to the same application fee as set forth for applications to the Township Zoning Board of Appeals on an appeal under [Section 5.5](#).

All applications under this Section 4.7 shall be accompanied by complete plans and specifications of the proposed improvements to the existing Dwelling or new unit if substitution of the Dwelling is requested.

All applications under this Section 4.7 shall be submitted on forms provided by the Township of Somerset.

#### **Section 4.8 – SITE PLAN REVIEW AND APPROVAL**

It is recognized by the Zoning Ordinance that there is a value to the public in establishing safe and convenient traffic movement to high density sites, both with the site and in relation to access roads; that there is value in encouraging a harmonious relationship of Buildings/Structures and Uses both within a site and in relation to adjacent Uses; further that there are benefits to the public in conserving natural resources. Toward this end, this Zoning Ordinance requires a Site Plan Review by the Township Zoning Administrator for certain Uses and Buildings/Structures that can be expected to have a significant impact on natural resources, traffic patterns, and in adjacent land usage.

##### **4.8.1 Buildings/Structures and Uses Requiring Site Plan**

The Township Zoning Administrator shall not issue a Zoning Compliance Permit for the construction of Buildings/Structures identified in this Section 4.8 unless a detailed Site Plan has been reviewed by the Township Zoning Administrator and the Township Board of Trustees.

- a. Multiple-family developments
- b. Mobile home park
- c. All Uses requiring a Conditional Use Plan
- d. All commercial Uses
- e. All industrial Use
- f. Site condominium developments

- g. Subdivision plats
- h. Commercially operated ORV park/trails
- i. Any development in a Commercial Zoning District or Industrial Zoning District

**4.8.2 Application and Fee for Site Plan Review**

Any person may file a request for a Site Plan Review by the Township Zoning Administrator by filing with the Township Clerk the completed application upon the forms furnished by the Township Clerk and payment of a fee established by resolution of the Township Board of Trustees. As an integral part of said application, the applicant shall file at least 4 copies of a Site Plan.

**4.8.3 Township Zoning Administrator Site Plan Review**

Upon receipt of such application from the Township Clerk, the Township Zoning Administrator shall undertake a study of the same and shall, within 30 days, approve or disapprove the Site Plan, advise the applicant in writing of the recommendation, including any changes or modifications in the proposed Site Plan as are needed to achieve conformity to the standards specified in this Zoning Ordinance.

**4.8.4 Required Data for Detailed Site Plan:** Every Site Plan submitted to the Township Zoning Administrator shall be in accordance with the following regulations:

- a. The Site Plan shall be of a scale not greater than 1 inch equals 20 feet and not less than 1 inch equals 200 feet. It shall be of such accuracy that the Township Zoning Administrator can readily interpret the Site Plan and shall include more than 1 drawing when required for clarity.
- b. The property shall be identified by Lot lines and location, including dimensions, angles and size, and correlate with the legal description of said property. Such Site Plan shall further include the name and address of each property owner, developer, and designer.
- c. The Site Plan shall show the scale; north point; boundary dimensions; topography (at least 2-foot contour intervals); and natural features, such as, wood, Lots, streams, rivers, lake drains, and similar features.
- d. The Site Plan shall show existing man-made features, such as Buildings/Structures; high tension towers; pipe lines; and existing utilities, such as water and sewer lines, excavations, bridges, culverts, drains, and easements, and shall identify adjacent properties and their existing Uses.
- e. The Site Plan shall show the location, proposed finished floor and grade line elevations, size of proposed Principal and Accessory Buildings/Structures, their relation one to another and to any existing Building/Structure on the site, the height of all Buildings/Structures, and square footage of floor space. Site Plans for residential development shall include a Dwelling schedule showing the unit type and number of each unit type.

- f. The Site Plan shall show the proposed roads, driveways, sidewalks, and other vehicular and pedestrian circulation features within and adjacent to the site; also, the location, size and number of parking spaces in the off-road parking area, and the identification of service lanes and service parking.
- g. The Site Plan shall show the proposed location, Use, and size of open land; and the location of any landscaping, fences, or walls on the site. Any proposed alterations to the topography and other natural features shall be indicated. The Site Plan shall further show any proposed location of connections to existing utilities and proposed extensions thereof.
- h. A vicinity map shall be submitted showing the location of the site in relation to the surrounding road system.

4.8.5 **Standards for Site Plan Review:** The Township Zoning Administrator shall ascertain whether the proposed Site Plan is consistent with all regulations of this Zoning Ordinance. Further, in consideration of each Site Plan, the Township Zoning Administrator shall find that provisions of Section 4.8.3 and Section 4.8.4 of this Zoning Ordinance as well as the provisions of the Zoning District in which said Buildings/Structures and Uses as indicated in the proposed Site Plan have been satisfactorily demonstrated and met by the applicant.

4.8.6 **Township Board of Trustees approval of Site Plans:** Upon the Township Zoning Administrator recommending approval of a Site Plan and Township Board of Trustees approval of the Site Plan, the Township Clerk shall, within 10 days transmit to the Township Zoning Administrator 1 copy with the Township Clerk's certificate affixed thereto; certifying that the approved Site Plan conforms to the provisions of the Zoning Ordinance as determined. If the Site Plan is disapproved by the Township Zoning Administrator or the Township Board of Trustees, notification of such disapproval shall be given to the applicant within 10 days after such action. The Township Zoning Administrator shall not issue a Zoning Compliance Permit until receipt of a certified approved Site Plan.

4.8.7 **Expiration of Township Clerk's certificate of Site Plans:** The Township Clerk's certificate of a Site Plan shall expire, and be of no effect, 365 days after the date of issuance thereof, unless within such time the Township Zoning Administrator has issued a Zoning Compliance Permit for any proposed work authorized under said Site Plan certificate.

4.8.8 **Amendment, revision of Site Plan:** A Site Plan, and the Township Clerk's certificate of the Site Plan, issued thereon, may be amended by the Township Planning Commission upon the request of the applicant. Such amendment shall be made upon application and in accordance with the procedure provided in Section 4.8 of this Zoning Ordinance. Any fees paid in connection with such application may be waived or refunded at the discretion of the Township Planning Commission.

#### **Section 4.9 – CONDITIONAL USES**

The formation and enactment of this Zoning Ordinance is based upon the division of the Township of Somerset into Zoning Districts in each of which are permitted specified Uses which are mutually compatible. In addition to such compatible Permitted Uses however, there are certain other Uses which may be necessary or desirable to allow in certain locations in certain Zoning Districts, but because of their actual or potential impact on neighboring Uses or public facilities, need to be carefully regulated with respect to their location for the protection of the Township of Somerset. Such Uses, on account of their peculiar locational need or the nature of the service offered, may have to be established in a Zoning District in which they cannot be reasonably allowed as a Permitted Use.



- 4.9.1 **Authority to Grant:** The Township Planning Commission, as hereinafter provided, shall have the authority to recommend to the Township Board of Trustees to grant Conditional Use Permits, subject to such conditions of design, operation, and safeguards as the Township Board of Trustees may determine for all Conditional Uses specified in the various provisions of this Zoning Ordinance.
- 4.9.2 **Application and Fee:** Application for any Conditional Use Permit permissible under the provisions of this Zoning Ordinance shall be made to the Township Planning Commission through the Township Clerk by filling in an official Conditional Use Permit application form; submitting required data, exhibits, and information; and depositing the required fee as established by resolution of the Township Board of Trustees, except that no fee shall be required of any governmental body or agency. No part of such fee shall be returnable to the applicant.
- 4.9.3 **Data, Exhibits, and Information Required in Application:** An application for a Conditional Use Permit shall contain the applicant's name and address in full, a statement that the applicant is the owner involved or is acting on the owner's behalf, the address of the property involved; an accurate survey drawing of said property showing the existing and proposed location of all Buildings/Structures thereon, the type thereof, and their Uses; and a statement of supporting data, exhibits, information, and evidence regarding the required findings set forth in this Zoning Ordinance.
- 4.9.4 **Public Hearings:** Refer to [Section 4.6](#) of the Zoning Ordinance.
- 4.9.5 **Required Standards and Findings for Making Determinations:** The Township Planning Commission shall review the particular circumstances and facts of each proposed Use in terms of the following standards and required findings, and shall find and record adequate written data, information, and evidence showing that such a Use on the proposed site, Lot, or parcel meets the following regulations:
- a. Will be harmonious with and in accordance with the general objectives, intent, and purposes of the Zoning Ordinance.
  - b. Will be designed, constructed, operated, maintained, and managed so as to be harmonious and appropriate in appearance with existing or intended character of the general vicinity.
  - c. Will be served adequately by essential public facilities and services, such as: roads, police and fire protection, drainage structures, refuse disposal, or that the persons or agencies responsible for the establishment of the proposed Use shall be able to adequately provide such service.
  - d. Will not be hazardous or disturbing to existing or future neighboring Uses.
  - e. Will not create excessive additional requirements at public cost for public facilities and services.
- 4.9.6 **Determination and Imposition of Conditions:** If the facts in the case do not establish beyond a reasonable doubt that the findings and standards set forth in the Zoning Ordinance shall apply to the proposed Use, the Township Planning Commission shall not recommend to the Township Board of Trustees that said should grant a Conditional Use Permit. In recommending that a Conditional Use Permit should be granted by the Township Board of Trustees, the Township Planning Commission shall recommend such conditions as it deems

necessary to protect the best interest of adjacent Lots and the Township of Somerset, and to achieve the objectives of the Zoning Ordinance. The decision on a Conditional Use Permit shall be incorporated in a statement of findings and conclusions relative to the Conditional Use Permit which specify the basis of the decision and any conditions imposed.

- 4.9.7 **Approval, Grant or Permit:** Upon holding a public hearing and the finding that the regulations of Section 4.9.2 through Section 4.9.6 of the Zoning Ordinance have been satisfactorily met by the applicant, the Township Planning Commission shall within 30 days recommend approval or disapproval to the Township Board of Trustees. The recommendation shall be incorporated in a statement of findings and conclusions which specified the basis for the recommendation and any conditions applied.

When the Township Board of Trustees gives approval, a Conditional Use Permit shall be issued to the applicant. The Township Board of Trustees shall forward a copy of the Conditional Use Permit to the applicant, the Township Clerk, the Township Zoning Administrator, and the Township Planning Commission. The Township Zoning Administrator shall not issue a Zoning Compliance Permit until the Township Zoning Administrator has received a copy of the Conditional Use Permit approved by the Township Board of Trustees.

- 4.9.8 **Voiding of Conditional Use Permit:** Any Conditional Use Permit granted under this Zoning Ordinance shall become null and void and fees forfeited unless construction and/or Use is commenced within 210 days and completed within 575 days of the day of issuance. A violation of a requirement, condition, or safeguard shall be considered a violation of this Zoning Ordinance and grounds for the Township Planning Commission to terminate and cancel such Conditional Use Permit.

#### **Section 4.10 – ADDITIONAL DEVELOPMENT REGULATIONS FOR CERTAIN CONDITIONAL USES**

A Conditional Use Permit shall not be issued for the Uses specified in this Section 4.10 unless complying with the site development regulations as herein specified. The Township Planning Commission may impose additional conditions and safeguards when deemed necessary by that body.

##### **4.10.1. Bed and Breakfast Facilities.**

- a. The minimum Lot size shall be 22,000 square feet. With a minimum frontage of 100 feet on a public road.
- b. A residence shall not have or be converted to more rental rooms than the number of bedrooms which exist at the time of adoption of this Zoning Ordinance.
- c. The minimum size of a rental room shall be 125 square feet.
- d. The minimum size for manager/owner living quarters shall be 450 square feet.
- e. A common room or area for guest relaxation is required.
- f. For those facilities which are not owner occupied, a manager must reside on the premises and have an equity interest in the facility.
- g. One off-road parking space shall be provided for each rental room in addition to the 2 off-road spaces required for 1-Family Dwellings. Parking shall be adequately screened from the adjacent Residential Zoning Districts or Lots containing Dwellings.
- h. Bathrooms must be furnished for guestrooms at a ratio of not less than 1 bathroom per 2 rental rooms.

- i. The premises (including corner Lots) may be permitted 1 advertising sign not exceeding 6 square feet in area.
- j. Approval by the Township Building Inspector is required prior to occupancy of the facility. Thereafter, the Township Building Inspector shall conduct an annual compliance inspection.
- k. Approval of the Branch-Hillsdale-St. Joseph Community Health Agency is required.
- l. The maximum stay at a bed and breakfast facility shall be 30 continuous days.
- m. The Use of the facility shall not, in the judgment of the Township Planning Commission and the Township Board of Trustees, be detrimental to adjacent land uses and the immediate neighborhood.

4.10.2. **Drive-In Theaters:** In addition to and as an integral part of development, the following provisions shall apply:

- a. Drive-in theaters shall be enclosed for their full periphery with a solid screen fence at least 7 feet in height. Fences shall be of sound construction, painted, or otherwise finished neatly and inconspicuously.
- b. All fenced-in areas shall be set back at least 100 feet from any front road or property line.
- c. All traffic ingress or egress shall be on county primary roads or state highways and all local traffic movement shall be accommodated within the site so that entering and exiting motorized vehicles will make normal and uncomplicated movements into or out of the public thoroughfare. All points of entrance to the exit of motorized vehicles shall be located closer than 200 feet from the intersection of any 2 roads.

4.10.3 **Funneling:** Conditional Use provisions in accordance with the Zoning Ordinance are hereby established to regulate land uses adjoining water bodies in any Zoning District.

The purpose of these regulations is to protect the public health, safety and welfare which could be threatened by environmental degradation resulting from the over-use of inland lakes, and to avoid situations which may create a nuisance, irreparably damage important natural resources and destroy property values. These regulations are intended to reinforce the implementation of the Natural Resources and Environmental Protection Act 1994 (PA 451 of 1994, [MCL 324.101 et. seq.](#)) as amended.

- a. **Definitions:** See [Section 6.1.6](#) for a definition of Funneling and associated terms.
- b. **Applicability:** These regulations shall apply to the following common-use riparian Lots:
  - 1. Those Lots created after the effective date of this Zoning Ordinance.
  - 2. Those Lots of record existing prior to the effective date of this Zoning Ordinance that did not provide common-use access to a water body (riparian rights to non-riparian landowners) prior to the effective date of this Zoning Ordinance.
  - 3. Lots that have been providing common-use access to a water body for a defined geographical area or a specific number of Lots through an association or subdivision/condominium deed prior to the effective date of this Zoning Ordinance, and where it is

proposed to expand the geographical area of the Lots that are provided common-use access to a water body through said common-use access Lot. Lots of record existing prior to the effective date of this Zoning Ordinance that have been providing common-use access to a water body for a defined geographical area or a specific number of Lots may continue to provide riparian access rights subject to existing deed provisions and the regulations of the Michigan Department of Environment, Great Lakes, and Energy (EGLE) under Part 301, Inland Lakes and Streams, of the Natural Resources and Environmental Protection Act, (PA 451 of 1994, [MCL 324.30101 et. seq.](#)), as amended.

c. **General Regulations:**

1. The deed to any common-use riparian Lot or parcel shall specify the non-riparian Lots or parcels that shall have rights to its use.
2. Such common-use riparian Lot or parcel shall meet the minimum Lot width and area regulations for the Zoning District in which the Lot is located. Lot width shall be measured by a straight line that intersects each side of the Lot line at the water's edge; Lot width shall be measured as the minimum distance between the water's edge and the Lot line that is opposite the water's edge.
3. For each non-riparian Lot or parcel being deeded common-use access, there shall be at least 40 feet of straight-line water frontage within the designated common-use riparian Lot.
4. Artificial shoreline, created by excavation, filling or other methods, may not be used to satisfy that riparian water-frontage requirement of this Zoning Ordinance.
5. Wetlands, as defined in Section 30301(1)(n), Part 303, Wetlands Protection, of the Natural Resources and Environmental Protection Act (PA 451 of 1994, [MCL 324.30301](#)), as amended, shall not be used to satisfy the riparian Lot frontage or depth regulations of this Zoning Ordinance.
6. Each non-riparian Lot or parcel with deeded common-use access may be allowed dock usage (subject to the regulations of [Section 4.10.11](#)); access for one boat; and bathing privileges for all property owners, their children and equal numbers of accompanied relatives or guests.
7. Vehicle and boat-trailer parking shall be provided for at least 15% of the non-riparian Lots or parcels having been deeded common-use access, with a setback of at least 80 feet from the water's edge and location within the rear 1/3 of the common-use riparian Lot.
8. A common-use riparian Lot, regardless of total area, shall not be used to contain a residence or storage Buildings/Structures, nor shall any outdoor storage, overnight parking, or commercial activities be allowed.

4.10.4 **Junk Yards:** In addition to and as an integral part of development, the following provisions shall apply:

- a. It is recognized by this Zoning Ordinance that the location of such materials in an open area included in this Zoning Ordinance's definition of junk yard (see [Section 6.1.10](#)) will cause the reduction of the value of adjoining property. To assure the character of

the Zoning District shall be maintained and property values conserved, a solid, unpierced fence or wall at least 7 feet in height, and not less than the height of the materials on the Lot on which a junk yard shall be operated, shall be located on said Lot no closer to the Lot lines than the yard regulations for Buildings/Structures permitted in this Zoning District. All gates, doors, and access ways through said fence or wall shall be of solid, unpierced material. In no event shall any materials included in this Zoning Ordinance's definition of "junk yard" be located on the Lot on which a junk yard shall be operated in the area between the lines of said Lot and the solid, unpierced fence or wall located on said Lot.

- b. All traffic ingress or egress shall be on county primary roads or state highways, and there shall be not more than 1 entrance way to the Lot on which a junk yard shall be operated from each public road on which said Lot abuts.
- c. All roads, driveways, parking Lots, and loading and unloading areas within any junk yard shall be paved, oiled, watered or chemically treated so as to limit adjoining Lots and public roads the nuisance caused by wind-borne dust.

4.10.5 **Mobile Home Parks:** All mobile home parks shall comply with the Department of Consumer and Industry Services, Manufactures Housing Commission, General Rules (by the authority conferred on the Mobile Home Commission by Sections 4, 5, 9, 21 to 24, 27, and 38 of The Mobile Home Commission Act (PA 96 of 1987, [MCL 125.2301 et. seq.](#)), as amended and Executive Order No. 1996-2 ([MCL 445.2001](#)).

4.10.6 **Mobile Home Subdivisions:**

- a. All mobile homes to be erected as permanent residences in mobile home subdivisions shall meet the regulations of the Michigan Building Codes and shall be approved by the Township Zoning Administrator prior to erection on the Lots.
- b. Each mobile home approved for erection on a mobile home subdivision Lot shall be mounted on a solid concrete apron no less than 12 feet in width, 60 feet in length and 4 inches in thickness or a suitable foundation.
- c. Lot areas where a mobile home is to be erected, altered, or used as a 1-Family Dwelling shall contain not less than 7,500 square feet of Lot area if the Lot is served by a central sanitary sewerage system. Where a Lot is not so served, there shall be provided a minimum of 15,000 square feet of Lot area for each mobile home.
- d. The minimum Lot width for Lots served with a central sanitary sewerage system shall be 60 feet. Where a Lot is not so served, the minimum Lot width shall be 120 feet.
- e. The maximum Lot coverage shall not exceed 30%.
- f. Each Lot in a mobile home subdivision shall have a front yard of not less than 35 feet.
- g. Each Lot in a mobile home subdivision shall have 2 side yards and the least width of either yard shall not be less than 10 feet, but the sum of the 2 side yards shall not be less than 25 feet.
- h. Each Lot in a mobile home subdivision shall have a rear yard of not less than 20 feet.
- i. No Building/Structure or part thereof, shall be erected to a height exceeding 15 feet.



- j. All mobile homes to be erected and used in a mobile home subdivision shall contain a gross floor area of not less than 500 square feet.

4.10.7 **ORV Park/Trails:** Commercially operated ORV Park/Trails for use by off-road vehicles, dune buggies, snowmobiles, off-road motorcycles and similar types of recreational vehicles are subject to the following terms:

- a. Any such site shall be located in existing compromised sites, such as borrow pits, mines or quarries with a minimum Lot area of 160 acres.
- b. Any such site shall minimize any adverse effect on adjacent properties.
- c. The site shall be so planned as to provide all ingress and egress directly onto a county primary road or state highway. There shall be adequate parking on-site.
- d. Trails or operation area shall be located at least 200 feet from any property line unless otherwise shown that a lesser set back would not adversely impact the adjoining property.
- e. Where such facilities adjoin property owned by third parties, there shall be adequate signage, clearly marking the borders and warning against trespass.
- f. A Site Plan shall be submitted to the Township Planning Commission for review and approval in accordance with [Section 4.8](#).
- g. The site shall stay in compliance with the Michigan State ORV noise regulations and any other applicable standards for protection of the natural resources and avoidance of undue interference with the use and enjoyment of adjacent property owners. The site shall comply with any applicable standards regarding participants and guests.

4.10.8 **Quarries:** The removal of soil, sand, gravel, stone, and other earth materials shall be subject to the following conditions:

- a. There shall be not more than 1 entrance way from a public road to said Lot for each 500 feet of front Lot line.
- b. Such removal, processing, transportation, and activities relating to storage such as stockpiling shall not take place before sunrise or after sunset.
- c. On said Lot, no digging or excavating shall take place closer than 100 feet to any Lot line.
- d. On said Lot, all roads, driveways, parking lots, and loading and unloading areas within 100 feet of any Lot line shall be paved, oiled, watered, or chemically treated so as to limit the nuisance of windborne dust to adjoining Lots and public roads.
- e. Any odors, smoke, fumes, or dust generated on said Lot by any digging, excavating, processing, stockpiling, or transportation operation and borne or able to be borne by the wind shall be confined within the lines of said Lot as much as it is possible so as not to cause a nuisance or hazard on any adjoining Lot or public road.
- f. Such removal processing or storage shall not be conducted as to cause the pollution by any material of any surface or subsurface, water-course, or body outside the lines of the Lot on which such Use shall be located.

- g. Such removal processing or storage shall not be conducted to cause or threaten to cause the erosion by water of any land outside of said Lot or of any land on said Lot so that earth materials are carried outside of the lines of said Lot. Nor shall such removal be conducted as to alter the drainage pattern of surface or subsurface waters on adjacent property. In the event that such removal, processing, or storage shall cease to be conducted, it shall be the continuing responsibility of the owner or operator thereof to assure that no erosion or alteration of drainage patterns, as specified in this paragraph, shall take place after the date of the cessation of operation.
- h. All fixed equipment and machinery shall be located at least 100 feet from any Lot line and 500 feet from any Residential Zoning District. In the event the zoning classification of any land within 500 feet of such equipment or machinery shall be changed to residential subsequent to the operation of such equipment or machinery, the operation of such equipment or machinery may continue henceforth, but in no case less than 100 feet from any Lot line.
- i. There shall be erected a fence not less than 6 feet in height around the periphery of the development. Fences shall be adequate to prevent trespass and shall be placed no closer than 50 feet to the top of any slope.
- j. All areas within any single development shall be rehabilitated progressively as they are worked out or abandoned to a condition of being entirely lacking in hazards, inconspicuous, and blended with the general surrounding ground so as to appear reasonably natural.
- k. The operator shall file with the Township Planning Commission and the Township Zoning Administrator detailed plans for the restoration of the development area which shall include the anticipated future Use of the restored land, the proposed final topography indicated by contour lines of not greater interval than 5 feet, steps which shall be taken to conserve topsoil; proposed and final landscaping; and the location of future roads, drives, drainage courses, and/or other improvements contemplated. Said plans shall be subject to review and modification from time to time by the Township Planning Commission. The anticipated cost of carrying out the plans for restoration shall be included with said plans.
- l. The operator shall file with the Township Board of Trustees a performance bond, payable to the Township of Somerset and conditioned on the performance of all regulations contained in the approved restoration plan. The amount of the required bond which will reflect the anticipated cost of restoration shall be fixed by the Township Board of Trustees. The bond shall be released upon written certification of the Township Zoning Administrator that the restoration is complete and in compliance with the restoration plan.

4.10.9 **Residential Uses in a Commercial Zoning District:** To encourage and provide for the economic vitality of Commercial Zoning Districts, residential occupancy shall be permitted.

- a. Businesses may occupy any number of total floors.
- b. In those instances where Residential Uses are proposed to occupy the same floor as the Commercial Use, the Township Planning Commission shall review such Mixed Use and may approve such Mixed Use based on findings that compatibility of the business with residential occupancy will occur. Such findings may include but are not limited to:



1. Compatible hours of operation.
  2. Noise of operation or occupancy that would be detrimental to the business operation or vice versa.
  3. Excessive foot traffic.
- c. A Use once established shall not require Township Planning Commission review. When a change of occupancy occurs, it shall not require Township Planning Commission review, provided such change of occupancy is of the same or a similar type Use.
- d. Each Dwelling Unit shall have a minimum floor area as follows:
1. Efficiency Dwelling Unit – 400 square feet
  2. 1-bedroom Dwelling Unit – 500 square feet
  3. 2- bedroom Dwelling Unit – 700 square feet
  4. 3-bedroom Dwelling Unit – 800 square feet
- e. Off-road parking shall be provided in accordance with [Section 3.6.7](#) and shall be provided in designated off-road parking areas within 1,000 feet of the Dwelling Unit the area is to serve.

**4.10.10 Wind Energy Conversion Systems:**

- a. The Township of Somerset promotes the effective and efficient use of Wind Energy Conversion Systems (WECS) with minimum regulation respecting their siting, design, and installation so that the public health, safety and welfare of neighboring property owners or occupants will not be jeopardized. This provision is not a guarantee or right to establish access to wind.
- b. **Definitions:** See [Section 6.1.23](#) for the definition of terms related to WECS.
- c. **Approval Required:** It shall be unlawful to construct, erect, install, alter, or locate any WECS within the Township of Somerset unless a Conditional Use Permit has been obtained pursuant to this Zoning Ordinance. The Conditional Use Permit shall be applied for pursuant to the submission of the documents and fees specified in [Section 4.9.2](#) and the provision of the following information:
  1. Plot plan which details the location of the WECS pole or tower, guy wire anchor bases, and their distance from all property boundaries.
  2. How the base of the WECS pole and/or other ground apparatus shall be appropriately protected and screened.
- d. General Standards applicable to all WECS in the Township of Somerset
  1. Design Safety Certification certified by a Professional Engineer and in compliance with the Conditional Use Permit application. Specifically, the Professional Engineer must certify that the rotor and over-speed control design and fabrication conform to applicable design standards. The Professional Engineer must also certify that the WECS meets or exceeds the manufacturer's construction and installation standards.

2. Manual and automatic controls which limit the rotation of blades to a speed at or below the designated limits of the WECS. No changes or alterations from certified design shall be permitted unless accompanied by a Professional Engineer's certification of such.
  3. Electrical components, storage facilities, wire conduit, cables and interconnections with an electric utility shall conform to United States, State of Michigan, County of Hillsdale, and/or Township of Somerset electrical codes.
  4. The WECS shall be in compliance with all applicable Ordinances of the Township of Somerset.
  5. The WECS must have a setback from all property boundaries at a distance equal to or greater than 150% of the height of the Structure, measured from the base of the Structure to the highest reach of its blade.
  6. Private WECS shall conform to the maximum height standards for the applicable Zoning District. Commercial WECS shall be exempt from the height regulations subject to the Conditional Use Permit and sustained compliance with FAA regulations.
  7. The owner/operator of the WECS must submit acceptable documentation which would determine whether the WECS would in any way cause interference with microwave transmissions, residential television reception, radio reception or other similar reception.
  8. The WECS shall have no fuel sources such as vegetation in the immediate vicinity of electrical gear and connections.
  9. All solid wastes, whether generated from supplies, equipment parts, packaging, operation or maintenance of the WECS, including old parts and equipment, shall be removed from the site immediately and appropriately disposed. All hazardous wastes generated by the WECS, including but not limited to the lubricating materials, shall be immediately removed from the site and properly disposed of according to all applicable law.
  10. The sound from the WECS shall not exceed 55 decibels when measured from any surrounding boundary line.
  11. The installation and operation of the WECS shall be properly and adequately insured with a bond acceptable to the Township of Somerset for a private WECS accessory to the principal residence. The owner must provide proof of adequate homeowner's insurance with specific coverage for the WECS.
- e. Additional Standards for Commercial WECS:
1. Towers and blades shall be painted any neutral color acceptable to the Township of Somerset or as otherwise required by law.
  2. Prior to the grant of the Conditional Use Permit by the Township of Somerset, the Commercial WECS shall have all applicable permits including that of the FAA; specifically, there shall be a determination by the FAA that there is no significant impact to air navigation.
  3. There shall be posted visible warning signs of "High Voltage."

4. Commencing twelve months from the actual month start date of the energy conversion, an Authorized Factory Representative or Professional Engineer shall annually inspect the Commercial WECS and certify to the Township of Somerset that the Commercial WECS is in good working condition and not a hazard to the public. Such certification shall be part of the continuing Conditional Use Permit.
5. If deemed necessary by the Township of Somerset, the Township of Somerset may require an avian study conducted by a qualified professional to determine any potential impacts on bird travel (i.e. bird migration) by the Commercial WECS.
6. All towers or poles must be non-climbable by design or protected by anti-climbing devices such as:
  - (a) Fences with locking portals at least 6 feet high.
  - (b) Anti-climbing devices 12 feet from the base of the pole.
  - (c) Anchor points for guy wires supporting the tower shall be enclosed by a 6-foot-high fence or shall be located within the confines of the property which is completely fenced; or
  - (d) Some other security method
7. There shall be a Decommissioning Plan to ensure proper decommissioning upon the end of the project life or facility abandonment. The Decommissioning Plan shall include the following:
  - (a) The removal of all surface Structures (such as transmission equipment and fencing), debris, and the establishment or restoration of vegetation within six months, commencing with the month in which ended the project life or facility abandonment.
  - (b) How the Commercial WECS shall be decommissioned; the Professional Engineer's estimated cost of the decommissioning; and the financial resources available to accomplish this decommissioning.
  - (c) An agreement with the Township of Somerset that the financial resources for decommissioning shall be in the form of a surety bond or deposit with an escrow agent acceptable to the Township of Somerset; the Township of Somerset shall have access to the escrow funds if the Commercial WECS is not decommissioned within six months of the end of the project life or facility abandonment; The Township of Somerset is granted access to the property to assure the Commercial WECS has been appropriately decommissioned and/or to complete the decommissioning; and the Township of Somerset is granted the right to seek injunctive relief, to seek monetary compensation in excess of the funds available through the escrow as needed to fulfill these obligations, and to resort to other remedies such as a lien whether against the applicant or successor in order to appropriately and reasonably complete the decommissioning.

4.10.11 **Residential Uses subject to a Conditional Use Permit:** Subject to the provisions in [Section 4.9](#), the following Uses may be permitted in any Residential Zoning District;

- a. Recreational sites, including bathing beaches, playgrounds, boat-launching sites, and other recreational sites;

- b. Scenic sites;
- c. Trails, bike paths, driveways, parking areas;
- d. Boat docks provided that all of the following regulations are met:
  - 1. 1 shared boat dock may be installed for every 2 non-riparian Lots in a subdivision/condominium with deeded common-use access.
  - 2. Boat docks may not exceed 4 feet in width nor extend further than 24 feet from, and perpendicular to, the shoreline or to a minimum distance at which a depth in the water of 4 feet is reached, whichever is less.
  - 3. Boat docks shall be used by only property owners with deeded common use access and their guests and may be leased, rented, or otherwise made available to guests not owning property in the subdivision/condominium.
  - 4. Boats moored overnight shall be attached to a boat dock.
  - 5. In addition to the above regulations, any boat dock must obtain a permit for marina operation from the Michigan Department Environment, Great Lakes, and Energy (EGLE) in accordance to Part 301, Inland Lakes and Streams, of the Natural Resources and Environmental Protection Act (PA 451 of 1994, [MCL 324.30101 et. seq.](#)), as amended. The design for a boat dock shall meet all of the marina standards set by the Michigan Department of Environment, Great Lakes, and Energy (EGLE).

**Section 4.11 – CONDOMINIUM SUBDIVISION PLAN APPROVAL**

Pursuant to authority conferred by Section 141 of the Condominium Act (PA 59 of 1978, [MCL 559.241](#)), as amended, all Condominium Subdivision Plans must be approved by the Township Board of Trustees on recommendation by the Township Planning Commission.

- 4.11.1 **Definitions:** See [Section 6.1.3](#) for definitions related to Condominium Subdivisions.
- 4.11.2. **Initial Information:** Concurrently with notice required to be given the Township of Somerset pursuant to Section 71 of the Condominium Act (PA 59 of 178, [MCL 559.171](#)), as amended, a person, firm or corporation intending to develop a condominium project shall provide the following information with respect to the project.
  - a. The name, address and telephone number of:
    - 1. All persons, firms, corporations with an ownership interest in the land on which the condominium project will be located together with a description of the nature of each entity’s interest (for example, fee owner, optionee, or land vendee).
    - 2. All engineers, attorneys, architects or registered land surveyors associated with the project.
    - 3. The developer or proprietor of the condominium project.
  - b. The legal description of the land on which the condominium projects will be developed together with the appropriate tax identification number.
  - c. The acreage content of the land on which the condominium projects will be developed.

- d. The purpose of the project (for example, residential, commercial, industrial).
  - e. Approximate number of Condominium Units to be developed in the subject parcel.
  - f. Whether or not a community septic system is contemplated.
- 4.11.3. **Information to be Kept Current:** The information shall be furnished to the Township Zoning Administrator and shall be kept updated until such time a certificate of occupancy has been issued pursuant to the Zoning Ordinance.
- 4.11.4. **Condominium Subdivision Plan – Required Content:** All Condominium Subdivision Plans shall include the information required by Section 66 of the Condominium Act (PA 59 of 178, [MCL 559.166](#)) and the following:
- a. A survey plan of the Condominium Subdivision.
  - b. A flood plain plan, where appropriate.
  - c. A plan showing the location, size, shape, area, and width of all Condominium Units.
  - d. A utility plan showing all sanitary sewers, water, and storm sewer lines and easements granted to the Township of Somerset for installation, repair and maintenance of all utilities.
  - e. A road construction, paving and maintenance plan for all private roads within the proposed Condominium Subdivision.
  - f. A storm drainage and storm water management plan, including all lines, swales, drains, basins, and other facilities.
- 4.11.5. **Site Plan Review — New Project, Master Deed, Engineering and Inspections:** Prior to recording the Master Deed required by Section 72 of the Condominium Act (PA 59 of 178, [MCL 559.172](#)), the condominium project shall undergo Site Plan Review and approval pursuant to [Section 4.8](#), Site Plan Review and Approval, of the Zoning Ordinance. In addition, the Township of Somerset shall require appropriate engineering plans and inspections prior to the issuance of any Certificate of Occupancy.
- 4.11.6. **Site Plan Review — Expandable or Convertible Projects:** Prior to expansion or conversion of a condominium project to additional land, the new phase of the project shall undergo Site Plan Review and approval pursuant to [Section 4.8](#), Site Plan Review and Approval, of the Zoning Ordinance.
- 4.11.7. **Easements for Utilities:** The Condominium Subdivision Plan shall include all necessary easements granted to the Township of Somerset for the purpose of constructing, operating, inspecting, maintaining, repairing, altering, replacing, and/or removing pipe lines, mains, conduits, and other installations of a similar character (hereinafter collectively called “Public Structures”) for the purpose of providing public utilities, including conveyance of sewage, water and storm water run-off across, through and under the property subject to said easement, and excavating and refilling ditches and trenches necessary for the location of said Public Structure.
- 4.11.8. **Private Roads:** If a Condominium Subdivision is proposed to have private roads, those roads shall be developed to the minimum design, construction, inspection, approval, and other applicable regulations of the Hillsdale County Road Commission for a dedicated public road.



- 4.11.9 **Encroachment Prohibited:** Encroachment of one Condominium Unit upon another, as described in Section 40 of the Condominium Act (PA 59 of 178, [MCL 559.140](#)), shall be prohibited by the condominium bylaws and recorded as part of the Condominium Subdivision Plan.
- 4.11.10 **Relocation of Boundaries:** The relocation of boundaries, as described in Section 48 of the Condominium Act (PA 59 of 148, [MCL 559.148](#)), shall conform to all setback regulations of this Zoning Ordinance for the Zoning District on which the project is located, shall be approved by the Township Zoning Administrator, and this requirement shall be made part of the bylaws as recorded as part of the Master Deed (as defined in [Section 6.1.3](#)).
- 4.11.11 **Subdivision of Condominium Units:** All subdivision or individual Condominium Units shall conform to the regulations of this Zoning Ordinance for a minimum Lot width and Lot area. The minimum yard setbacks for Buildings/Structures shall be approved by the Township Zoning Administrator, made part of the bylaws, and recorded as part of the Master Deed.
- 4.11.12 **Mobile Home Condominium Project:** Mobile home condominium projects shall conform to all regulations of this Zoning Ordinance and shall be located in all mobile home subdivisions.
- 4.11.13 **Condominium Subdivision Layout, Design, and Approval:** All Condominium Subdivision Plans shall conform to the plan preparation regulations, review and approval procedures, design, layout and improvements standard of [Section 4.8](#), Site Plan Review and Approval, of the Zoning Ordinance. A deposit in the form of cash, certified check, or irrevocable bank letter of credit shall be made with the Township of Somerset, if required by the Township Board of Trustees, to guarantee the installation and completion on any required public sanitary sewer, water supply, and drainage facilities within a length of time agreed upon from the date of final approval of the Condominium Subdivision Plan by the Township Board of Trustees.
- 4.11.14. **Master Deed, Restrictive Covenants and “As Built” Survey to be Finished:** The condominium project developer or proprietor shall furnish the Township Zoning Administrator with the following: 1 copy of the recorded Master Deed, 1 copy of all restrictive covenants, and 2 copies of an “as built” survey. The “as built” survey shall be reviewed by the Township Zoning Administrator for consistency with the approved Condominium Subdivision Plan. Fees for this review shall be established by resolution of the Township Board of Trustees.
- 4.11.15. **Monuments Required for Site Condominium Project:** Condominium projects which consist in whole or in part of Condominium Units which are permanent Buildings/Structures, Mobile Homes, or recreational sites, shall be marked with monuments as provided in this Section 4.11.15.
- a. Monuments shall be located in the ground and made according to the following regulations, but it is not intended or required that monuments be placed within the traveled portion of a road or mark angles in the boundary of the condominium project, if the angle points can be readily reestablished by reference to monuments along the sidelines of the road.
  - b. All monuments used shall be made of solid iron or steel bars at least ½ inch in diameter and 36 inches long and completely encased in concrete at least 4 inches in diameter.
  - c. Monuments shall be located in the ground at all angles in the boundaries of the condominium project; at the intersection lines of roads and at the intersection of the lines of roads with the boundaries of the condominium project and at the intersection of alleys

with the boundaries of the condominium project; at all points of curvature, points of tangency, points of compound curvature, and angle points in the side lines of roads and alleys; at all angles of an intermediate traverse line and at the intersection of all limited common elements.

- d. If the required located monument is an inaccessible place, or where the location of a monument would be clearly impracticable, it is sufficient to place a reference monument nearby and the precise location thereof be clearly indicated on the plans and referenced to the true point.
- e. If a point required to be monumented is on bedrock outcropping, a steel rod at least ½ inch in diameter shall be drilled and grouted into solid rock to a depth of at least 8 inches.
- f. All required monuments shall be placed flush with the ground where practicable.
- g. All unit corners shall be mounted in the field by iron or steel bars or iron pipes at least 18 inches long and ½ inches in diameter or other approved markers.
- h. The Township Board of Trustees may wave the placing of any required monuments for a reasonable time, but not to exceed 1 year, on the condition that the proprietor deposits with the Township Clerk cash or a certified check, or irrevocable bank letter of credit turning to the Township of Somerset, whichever the proprietor selects, in any amount not less than that established for this purpose by resolution of the Township Board of Trustees. Such cash, certified check, or irrevocable bank letter of credit shall be returned to the proprietor upon receipt of a certificate by surveyor that the monuments have been placed as required within the time specified.

- 4.11.16. **Monuments Required – All Condominium Projects:** All condominium projects shall be marked at their boundaries with monuments meeting the regulations of Section 4.11.15, above.
- 4.11.17. **Compliance with United States and State of Michigan statutes and County of Hillsdale and Township of Somerset Ordinances:** All condominium projects shall comply with United States and State of Michigan statutes and County of Hillsdale and Township of Somerset Ordinances.
- 4.11.18. **State of Michigan and County of Hillsdale Approval:** The developer or proprietor of the condominium project shall establish that appropriate State of Michigan and County of Hillsdale approvals have been received with regard to the fresh water system for the proposed project and with regard to the wastewater disposal system for the proposed project.
- 4.11.19. **Temporary Occupancy:** The Township Zoning Administrator may allow occupancy of the condominium project before all improvements required by this Zoning Ordinance are installed provided that a bond is submitted sufficient in the amount and type to provide for the installation and improvements before the expiration of the temporary occupancy permit without expense to the Township of Somerset.
- 4.11.20 **1-Family Detached Condominium:** A 1-family detached condominium shall be subject to all regulations and standards of the applicable Agricultural and Residential Districts including minimum floor area regulations and minimum Lot size. For the purpose of computing density, the number of units per gross acre shall not exceed 2.9 units per acre in developments without community water and sanitary sewer systems, or 3.8 units per acre in developments with community water and sanitary sewer systems. There shall be maintained



a minimum distance of 70 feet from the center of 1 residential Dwelling Unit to the center of another residential Dwelling Unit. This 70-foot requirement shall be computed along the front building line. In addition, buildings shall be depicted/dimensioned in some way on the Site Plan to show that the minimum 50-foot front yard, 20-foot rear yard, 20-foot side set yard (least side) are adhered to.

- 4.11.21 **Multiple-Family Condominium:** 2-Family or Multiple-Family Condominiums shall be located only in those Zoning Districts allowing 2-Family or Multiple-Family Dwellings, and shall be subject to all of the zoning regulations and standards of the Zoning District in which they are located. Such standards shall include but not be limited to minimum floor area regulations, minimum Lot size, and the setback regulations of the Zoning Ordinance for the Zoning District in which the project is located.
- 4.11.22 **Roads:** All roads in a 1-Family detached condominium project shall, at minimum, conform to the standards and specifications promulgated by the Hillsdale County Road Commission for roads in a 1-Family residential subdivision.
- 4.11.23 **Condominium Subdivision Plan:** After submittal of the Condominium Subdivision Plan and bylaws as part of the Master Deed, the proprietor shall furnish to the Township of Somerset a digital and hard copy of the Condominium Subdivision Plan.

#### **Section 4.12 – AMENDMENT PROCEDURES**

- 4.12.1 **Initiating Amendments and Fee:** The Township Board of Trustees may, from time to time, on recommendation from the Township Planning Commission on its own motion, amend, modify, supplement, or revise any Zoning District boundaries or the provisions and regulations herein established whenever the public necessity and convenience and the general welfare require such amendment.  

Said amendment may be initiated by resolution of the Township Board of Trustees, the Township Planning Commission, or by petition of one or more owners of property to be affected by the proposed amendment. Except for the Township Board of Trustees or the Township Planning Commission, the petitioner requesting an amendment shall at the time of application pay the fee established by resolution of the Township Board of Trustees no part of which shall be returnable to the petitioner.
- 4.12.2 **Amendment Procedures:** The procedure for making amendments to this Zoning Ordinance shall be in accordance with Article IV of the Michigan Zoning Enabling Act (PA 110 of 2006, [MCL 125.3401 et. seq.](#)), as amended.
- 4.12.3 **Conformance to Court Decree:** Any amendment for the purpose of conforming to a provision of a court decree shall be adopted by the Township Board of Trustees and the amendments published without referring the same to another board or agency.

## **Article V**

### **TOWNSHIP ZONING BOARD OF APPEALS**

#### **SECTION 5.1 – TOWNSHIP ZONING BOARD OF APPEALS**

The Township Zoning Board of Appeals shall perform its duties and exercise its powers as provided in Article VI of the Michigan Zoning Enabling Act (PA 110 of 2006, [MCL 125.3601 et. seq.](#)) in such a way so that the objectives of the Zoning Ordinance shall be observed, the public health and safety secured, and substantial justice done.

- a. The Township Zoning Board of Appeals shall be composed of 5 regular members for staggered 3-year terms, per the regulations of Section 601 of the Michigan Zoning Enabling Act (PA 110 of 2006, [MCL 125.3601](#)), as amended. One of the regular members of the Township Zoning Board of Appeals shall be a member of the Township Planning Commission. The remaining regular members, and any alternate members, shall be selected from the electors of the Township of Somerset. Membership vacancies must be filled within 1 month.
- b. The Township Board of Trustees may remove a member of the Township Zoning Board of Appeals for misfeasance, malfeasance, or nonfeasance in office upon written charges after a public hearing. The failure of a members to disqualify themselves when they have a conflict of interest constitutes malfeasance in office.
- c. The Township Board of Trustees may appoint up to 2 alternate members to the Township Zoning Board of Appeals for the same term as regular members. An alternate member would be called to serve as a member in the absence of a regular member if the regular member is unable to attend 1 or more meetings. An alternate member may also be called to serve as a member for the purpose of reaching a decision on a case in which a regular member has abstained for reasons of conflict of interest.

#### **SECTION 5.2 – DUTIES OF THE TOWNSHIP ZONING BOARD OF APPEALS**

The Township Zoning Board of Appeals shall hear and decide only such matters as the Township Zoning Board of Appeals is specifically authorized to pass on as provided in this Zoning Ordinance. The Township Zoning Board of Appeals shall not have the power to alter or change the Zoning District classification of any property; nor to make any changes in the terms of this Zoning Ordinance; but does have the power to authorize a variance as defined in this Zoning Ordinance, to act on those matters where this Zoning Ordinance may require an interpretation, and to issue a Temporary Use Permit when authorized by this Zoning Ordinance.

#### **SECTION 5.3 – VARIANCE**

The Township Zoning Board of Appeals may authorize, upon an appeal, a variance from the Zoning Ordinance where by reason of narrowness, shallowness, shape, or contour of a specific property at the time of enactment of this Zoning Ordinance or by reason of conditions of such property, the strict application of the Zoning Ordinance enacted would result in practical difficulties upon the owner of such property. No variance shall be granted to permit the establishment within a Zoning District of any Use which is excluded or for which a Conditional Use Permit is required.

A variance from the terms of this Zoning Ordinance shall not be granted by the Township Zoning Board of Appeals unless and until:

- a. A written application for a variance is submitted, demonstrating the following:
  1. That special conditions and circumstances exist which are peculiar to the land or Building/Structure involved and which are not applicable to other land or Buildings/Structures in the same Zoning District.
  2. That literal interpretation of the provisions of this Zoning Ordinance would deprive the applicant of rights commonly enjoyed by other properties in the same Zoning District under the terms of this Zoning Ordinance.
  3. That the special conditions and circumstances do not result from the actions of the applicant.
  4. That granting the variance requested will not confer on the applicant any special privilege that is denied by this Zoning Ordinance to other lands or Buildings/Structures in the same Zoning District.
  5. That no Nonconforming Use of neighboring lands or Buildings/Structures in the same Zoning District, and no Permitted Use of lands or Buildings/Structures in other Zoning Districts shall be considered grounds for the issuance of a variance.
- b. The Township Zoning Board of Appeals shall determine that any other applicable regulations of the Zoning Ordinance have been met by the applicant for a variance.
- c. The Township Zoning Board of Appeals shall determine that the reasons set forth in the application justify the granting of the variance, and the variance is the minimum variance that will make possible the reasonable Use of the land or Building/Structure.
- d. The Township Zoning Board of Appeals shall determine that the granting of the variance will be in harmony with the general purpose and intent of this Zoning Ordinance, and will not be injurious to the neighborhood, or otherwise detrimental to the public welfare.
- e. In granting any variance, the Township Zoning Board of Appeals may prescribe appropriate conditions and safeguards in conformity with this Zoning Ordinance. Violations of such conditions and safeguards, when made a part of the terms under which the variance is granted, shall be deemed a violation of this Zoning Ordinance.
- f. Each variance granted under the provisions of this Zoning Ordinance shall become null and void unless:
  1. The construction authorized by such variance or permit has been commenced within 180 days after the granting of such variance and pursued diligently to completion; or
  2. The occupancy of land or Buildings/Structures authorized by such variance has taken place within 180 days after the granting of such variance.
- g. No application for a variance which has been denied wholly or in part by the Township Zoning Board of Appeals shall be resubmitted for a period of 365 days from such denial, except on grounds of new evidence or proof of changed conditions found by the Township Zoning Board of Appeals to be valid.

## SECTION 5.4 – INTERPRETATION OF ZONING ORDINANCE

The Township Zoning Board of Appeals shall hear and decide appeals where it is alleged by the applicant there is an error in any order, requirement, permit, decision, or refusal made by the Township Zoning Administrator or any other administrative official in carrying out or enforcing any provisions of this Zoning Ordinance including interpretations of the Township of Somerset Official Zoning Map.

## SECTION 5.5 – APPEALS TO THE TOWNSHIP ZONING BOARD OF APPEALS

- 5.5.1 **Appeals, How Taken:** Appeal from the ruling of the Township Zoning Administrator or the Township Board of Trustees concerning the enforcement of the provisions of this Zoning Ordinance may be made to the Township Zoning Board of Appeals within such time as shall be prescribed by the Township Zoning Board of Appeals by general rule, by the filing with the officer from whom the appeal is taken. This officer shall forthwith transmit to the Township Zoning Board of Appeals all the papers constituting the record upon which the action appealed was taken.
- 5.5.2 **Why May Appeal:** Appeals to the Township Zoning Board of Appeals may be taken by any person aggrieved or by any officer, department, board, agency, or bureau of the Township of Somerset, County of Hillsdale, and/or State of Michigan.
- 5.5.3 **Fee for Appeals:** A fee prescribed by the Township Zoning Board of Appeals shall be paid to the Township Zoning Board of Appeals at the time of filing the notice of appeal which the Township Zoning Board of Appeals shall pay over, within 30 days after deciding any appeal, to the General Fund of the Township of Somerset.
- 5.5.4 **Effect of Appeal; Restraining Order:** An appeal stays all proceedings in furtherance of the action appealed unless the Township Zoning Administrator certifies to the Township Zoning Board of Appeals, after the notice of appeal shall have been filed with the Township Zoning Administrator. If by reason of facts stated in the certificate, a stay would in the Township Zoning Administrator's opinion cause imminent peril to life or property, proceedings shall not be stayed other than by a restraining order which may be granted by the Township Zoning Board of Appeals or by the Circuit Court, on application, of notice to the Zoning Administrator and on due cause shown.
- 5.5.5 **Notice of Hearing:** Refer to [Section 4.6](#) of the Zoning Ordinance.
- 5.5.6 **Representation of Hearing:** Upon the hearing, any party or parties may appear in person, by agent, or by attorney.
- 5.5.7 **Decisions of the Township Zoning Board of Appeals and Appeals to the Circuit Court:** The Township Zoning Board of Appeals shall decide upon all matters within a reasonable time and may reverse or affirm wholly or partly, or may modify the order, requirement, decision or determination appealed from and shall make such order, requirement, decision or determination as in its opinion ought to be made in the premises and to that end shall have all the powers of the Township Zoning Administrator or Township Board of Trustees from whom the appeal is taken.

The Township Zoning Board of Appeals' decision of such appeals shall be in the form of a resolution containing a full record of the findings and determination of the Township Zoning Board of Appeals in each particular case. Any person having an interest aggrieved by such resolution shall have the right to appeal to the Circuit Court a question of law and fact in which case proceedings shall not be

stayed other than by a restraining order which may be granted by the Township Zoning Board of Appeals or by the Circuit Court, on application of notice to the Township Zoning Administrator and on due cause shown.

## **Article VI**

### **DEFINITIONS AND UNDEFINED TERMS**

#### **Section 6.1 - DEFINITIONS**

For the purpose of this Zoning Ordinance certain terms are herewith defined. When not inconsistent with the context, the present tense includes the future; the words used in the singular number include the plural number, and the plural, the singular. The word “shall” is always mandatory and not merely suggestive. The word “person” includes a firm, association, organization, partnership, trust, company, or corporation as well as an individual. The words “used” or “occupied” include the words “intended”, “designed”, or “arranged” to be used or occupied.

##### **6.1.1 ‘A’ Definitions**

**Accessory Building/Structure or Use:** A detached Building/Structure or Use on the same Lot with and of a nature customarily incidental and subordinate to the Principal Building/Structure or Use. An Accessory Building/Structure shall not be intended for human occupancy unless otherwise permitted.

**Alley:** A public or private way not more than 33 feet wide which affords only a secondary means of access to abutting property.

**Alter:** Any structural change in the supporting or load bearing part of a Building/Structure, such as bearing walls, columns, beams, girders, or foot jacks.

**Apartment:** A Dwelling Unit in an apartment house arranged, designed, or occupied as a residence by 1 family, individual, or group of individuals.

##### **6.1.2 ‘B’ Definitions**

**Basement:** A story of a Building/Structure having more than one-half its height below grade.

**Bed and Breakfast Facility:** A Building/Structure, typically a large 1-Family Dwelling, where lodgings and light breakfast are provided to persons, other than the resident family, for compensation.

**Boarding House or Rooming House:** A Building/Structure where, through compensation, meals and/or lodging are provided to persons by pre-arrangement for definite periods of time.

**Building/Structure:** A covered Building/Structure designed primarily for the shelter, support, or enclosure of persons, animals, or property of any kind. Buildings/Structures may be above or below ground and take the form of Mobile Homes, mobile Buildings/Structures, or pre-manufactured or pre-cut Buildings/Structures.

**Building/Structure Height:** The vertical distance measured from grade to the highest point of the roof for flat roofs, to the deck line of measure roofs, and to the average height between eaves and ridges for gable, hip, or gambrel roofs.

**Building/Structure Setback Line:** A line parallel to or concentric with property lines delineating the minimum allowable distance between the road right-of-way and the front of the Building/Structure.



6.1.3 **‘C’ Definitions**

**Camp:** A place where tents, huts, cabins, barracks, or other more or less temporary Buildings/Structures or group of these are put up for the purpose of temporary lodging.

**Campgrounds (includes camping grounds):** A place where a camp is set up or is allowed to be set up, for a fee.

**Central Sanitary Sewage System:** Any person, firm, corporation, municipal department, or board duly authorized to furnish or furnish-ing under United States, State of Michigan, County of Hillsdale and/or Township of Somerset Ordinances to the public a central sanitary sewer system from a central location or plant.

**Central Water System:** Any person, firm, corporation, municipal department, or board duly authorized to furnish or furnishing under United States, State of Michigan, County of Hillsdale and/or Township of Somerset Ordinances to the public a central water system from a central location or plant.

**Condominium Subdivisions:** The following terms are defined both in the context of the Condominium Act (PA 59 of 1978, [MCL 559.101 et. seq.](#)), as amended, and in a manner intended to make comparison possible between the terms of this Zoning Ordinance with the Condominium Act.

- a. **“Condominium Act”** means the Condominium Act (PA 59 of 178, [MCL 559.101 et. seq.](#)), as amended.
- b. **“Condominium Subdivision”** shall be equivalent to the term “subdivision” as used in this Zoning Ordinance.
- c. **“Condominium Subdivision Plan”** means the site, survey and utility plans; and sections, as appropriate, showing the existing and proposed Building/Structure and improvements including the location of the land. The Condominium Subdivision Plan shall show the size, location, area, vertical boundaries, and volume of each unit comprised of enclosed air space. A number shall be assigned to each Condominium Unit. The Condominium Subdivision Plan shall include the nature, location, and appropriate size of common elements.
- d. **“Condominium Unit”** means that portion of the condominium project designed and intended for separate ownership and use, as described in the Master Deed, regardless of whether it is intended for residential, office, industrial, business, recreational, use as a time-share unit, or any other type of use.
- e. **“Consolidation Unit”** means the portion of the Condominium Unit designed and intended for separate ownership and Use, as described in the Master Deed.
- f. **“Lot”** shall mean the same as the Condominium Unit.
- g. **“Mobile Home Condominium Project”** means a condominium project where mobile homes are intended to be located upon separate sites which constitute individual Condominium Units.
- h. **“Master Deed”** means the condominium documents recording the condominium project as approved by the Township Zoning Administrator to which is attached as exhibits and incorporates by reference in the approved bylaws of the project and the approved Condominium Subdivision Plan for the project.



6.1.4 **'D' Definitions**

**Day Care Center:** A facility for the care of children under 18 years of age, as licensed and regulated by Childcare Organization (PA of 1973, [MCL 722.111 et seq.](#)) as amended, and the associated regulations.

**Double Frontage Lot:** An interior Lot having frontage on 2 parallel or approximately parallel roads.

**Drive-In Establishment:** A business establishment so developed that its retail or service character is primarily dependent on providing a driveway approach or parking spaces for motorized vehicles as well as within the Building/Structure.

**Dwelling Unit:** One or more rooms with independent cooking facilities designed as a unit for residence by only 1 family.

**Dwellings:**

- a. **1-Family Dwellings:** Detached Buildings/Structures, designed for or occupied by a single family, complying with the following standards.
  1. It has a minimum living area of 750 sq. ft. for a 1- or 2-bedroom Dwelling Unit plus 150 sq. ft. of additional living area for each additional bedroom beyond 2.
  2. It has a minimum width along all exterior side elevations of 20 ft.
  3. It is firmly attached to a solid foundation in accordance with the Michigan Building Codes and is co-extensive with the perimeter of the Building/Structure, which attachment shall also meet all Building Codes, other Michigan regulations, and, in the case of manufactured housing, the specifications of the manufacturer concerning foundation support.
  4. It does not have exposed wheels, towing mechanisms, undercarriage or chassis.
  5. The Dwelling is aesthetically compatible in design and appearance with other residences in the vicinity, with no less than 2 exterior doors with 1 being in the front of the Dwelling and the other being in either the rear or side of the Dwelling, and with a roof pitch of 3/12.
  6. The compatibility of design and appearance shall be determined in the first instance by the Township Zoning Administrator upon review of the plans submitted for a particular Dwelling, subject to appeal by the aggrieved party to the Township Zoning Board of Appeals within a period of 15 days from the receipt of notice of said Township Zoning Administrator's decision. Any determination of compatibility shall be based upon: (a) The standards set forth in the within definition of "Dwelling", (b) the character of residential development outside of Mobile Home Parks and Mobile Home Residential Districts within 2,000 feet of the subject Dwelling where such area is developed with Dwellings to the extent of not less than 20% of said area or (c) where said area is not to be developed, by the character of residential development outside of Mobile Home Parks and Mobile Home Subdivisions, throughout the Township of Somerset. The foregoing shall not be construed to prohibit innovative design concepts involving such matters as solar energy, view, unique land contour, or relief from the common or standard designed Dwelling.

7. The Dwelling is connected to a public sewer and water supply or to such private facilities approved by the Branch-Hillsdale-St. Joseph Community Health Agency.
  8. The Dwelling must comply with the National Electric Code and Township of Somerset's building, plumbing and fire codes, including, in the case of mobile homes, the standards for mobile home construction as contained in the United States Department of Housing and Urban Development (HUD) regulations entitled Mobile Home Construction and Safety Standards, effective June 15, 1976, as amended.
  9. The Dwelling contains no additions, rooms or other areas other than as approved with compatible materials, in compatible appearance, and with quality of workmanship similar to the original Building/Structure, including the above described foundation and permanent attachment to the Principal Building/Structure.
  10. The foregoing standards shall not apply to a mobile home located in a licensed mobile home park except to the extent required by United States or State of Michigan law or otherwise specifically required in the Zoning Ordinance of the Township of Somerset.
- b. **2-Family Dwellings:** A Building/Structure containing not more than 2 separate Dwelling Units designed for Residential Use and conforming in all other respects to the standards set forth in the definition for 1-Family Dwellings.
  - c. **Multiple-Family Dwellings:** A Building/Structure containing three or more Dwelling Units designed for Residential Use and conforming in all other respects to the standards set forth in the definition for 1-Family Dwellings.

#### 6.1.5 'E' Definitions

**Easement:** Any private or dedicated public way other than a road or alley providing a secondary means of access to a property having a width of no less than 20 feet.

**Essential Services:** The erection, construction, alteration, or maintenance by public utilities or municipal departments, commissions, or boards, of underground, surface, or overhead gas, electric, steam or water transmission or distribution systems, collection of communication, supply or disposal systems, including poles, wires, drains, sewers, pipes, towers, conduits, cables, fire alarm boxes, police call boxes, similar equipment and accessories in connection therewith, for the general public health, safety, convenience, or welfare, but not including Buildings/Structures or maintenance depots.

#### 6.1.6 'F' Definitions

**Family:** One or more persons living together in a room or rooms comprising a single housekeeping unit and including the domestic employees hereof. A family is distinguished from a group occupying a rooming-house, boarding-house, lodging-house, club, fraternity-house, hotel, motel, or tourist home.

**Finished Grade** means the finished ground level of an area adjoining the Building/Structure after construction is completed. For purposes of measurement, the portion of the Building/Structure that faces the road or having predominant road frontage shall be used.

**Funneling:**

- a. **Funneling/Keyholing.** The use of a riparian Lot to provide access to non-riparian property owners.
- b. **Common Use Riparian Lot.** A common use riparian Lot (also referred to as a keyhole Lot) is defined as any private site, platted Lot or other parcel held in common by a subdivision, association, similar agency or group of individuals, or held in common by virtue of the terms of a plot of land of record which provides common use riparian access to non-riparian Lot or land owners.

6.1.7 **‘G’ Definitions**

Reserved

6.1.8 **‘H’ Definitions**

**Home Occupation:** An occupation that is appropriately carried on the home being primarily incidental to the Principal Residential Use.

**Hotel:** A Building/Structure containing guest rooms in which, for compensation, lodging is provided, with or without meals, and which is open to transient or permanent guests, or both, and where no provision is made for cooking in any guest room.

6.1.9 **‘I’ Definitions**

Reserved

6.1.10 **‘J’ Definitions**

**Junkyard:** A Building/Structure or parcel of land where junk, waste, discard, salvage, or similar materials such as iron or other metal, wood, lumber, glass, paper, rags, cloth, leather, rubber, bagging, cording, barrels, containers are bought, sold, exchanged, stored, baled, packed, disassembled, or handled including motorized vehicle wrecking yards, inoperative machines, used lumber yards, house wrecking, and structural steel materials, and equipment including establishments for sale, purchase, or storage of salvaged machinery and the processing of used, discarded, or salvaged materials, for any 30 consecutive days.

6.1.11 **‘K’ Definitions**

**Kenel:** Any Lot or premises on which 3 or more dogs, 4 months old or more are confined either permanently or temporarily.

6.1.12 **‘L’ Definitions**

**Lot:** A parcel of land of at least sufficient size to meet minimum zoning regulations for Use, coverage, and area; and to provide such yards and other open land as herein required. Such Lot may consist of a single Lot of record; a portion of a Lot of record; a combination of contiguous Lots of record; or a parcel of land described by metes and bounds.

**Lot Area:** The area within the Lot lines, but excluding that portion in a road right-of-way.

**Lot Corner:** A parcel of land at the junction of and fronting or abutting on 2 or more intersecting roads.

**Lot Coverage:** The part or percent of the Lot occupied by a Building/Structure, including an Accessory Building/Structure.

**Lot Depth:** The average distance between the front and rear line of a Lot measured in the general direction of its side Lot lines.

**Lot of Record:** A Lot which: (1) is part of a recorded subdivision and is shown on a map thereof which has been recorded with the Hillsdale County Register of Deeds or (2) a Lot described by metes and bounds, the deed to which has been recorded with the Hillsdale County Register of Deeds.

### 6.1.13 'M' Definitions

**Medical Marijuana:** The following terms are associated with medical marijuana as regulated by the Township of Somerset:

- a. **Marijuana:** Marijuana, according to Michigan's Public Health Code (PA 368 of 1978, [MCL 333.1101, et. seq.](#)), "means all parts of the plant Cannabis sativa L., growing or not; the seeds thereof; the resin extracted from any part of the plant; and every compound, manufacture, salt, derivative, mixture, or preparation of the plant or its seeds or resin. It does not include the mature stalks of the plant, fiber produced from the stalks, oil or cake made from the seeds of the plant, any other compound, manufacture, salt, derivative, mixture, or preparation of the mature stalks, except the resin extracted therefrom, fiber, oil or cake, or the sterilized seed of the plant which is incapable of germination."
- b. **Medical marijuana:** Medical marijuana, according to the Michigan Medical Marijuana Act (MMMA), "means the acquisition, possession, cultivation, manufacture, use, internal possession, delivery, transfer, or transportation of marijuana or paraphernalia relating to the administration of marijuana to treat or alleviate a registered patient's debilitating medical condition or symptoms associated with the debilitating medical condition."
- c. **Michigan Medical Marijuana Act (MMMA):** The MMMA ([MCL 333.26421 et. seq.](#)) is an initiation of legislation to allow under Michigan law the medical use of marijuana; provide protections for the medical use of marijuana; and provide for a system of registry identification cards for qualifying patients and primary caregivers. The MMMA is supplemented by administrative rules promulgated by the Michigan Department of Health and Human Services (MDHHS) ([R 333.101 et seq.](#)). The MMMA defines the following specific categories of people.
- d. **Primary caregiver:** A primary caregiver is an individual, as defined by the MMMA, and is authorized by and registered through the Michigan Department of Health and Human Services (MDHHS) to grow and distribute medical marijuana to qualified patients. The primary caregiver must have a valid registry card.
- e. **Qualifying patient:** A qualifying patient is an individual, as defined by the MMMA, that has been diagnosed by a licensed physician, as defined by the MMMA, as having a medical condition alleviated by the use of medical marijuana, and who is registered to grow and/or consume medical marijuana. The qualifying patient must have a valid registry card.
- f. **Medical marijuana caregiver grow operation:** A medical marijuana caregiver grow operation is an establishment used by 1 registered primary caregiver for the purposes of the growing and dispensing of medical marijuana outside the privacy of a personal Dwelling for up to 5 qualifying patients (as well as the caregiver if the caregiver is also a qualifying patient), but where there is no consumption of marijuana on the premises.
- g. **Medical marijuana home use:** A medical marijuana home use is a Dwelling where a qualifying patient grows or uses medical marijuana for personal consumption in the privacy of their own Dwelling, and/or where a registered primary caregiver,

serving not more than 1 qualifying patient who resides with the primary caregiver, grows or distributes medical marijuana for the qualifying patient in the privacy of the primary caregiver's own Dwelling, and is allowed as a use by right wherever Dwellings are permitted.

**Mini-Storage or Self-Storage:** A Building/Structure or group of Buildings/Structures in a controlled access or fenced area that contains varying sizes of individual compartmentalized units, which are accessed by separate exterior doorways for each unit, designed for the storage of property for individuals, organizations, and businesses. These are also known as "self-storage facilities" or "mini-warehouse facilities".

**Mobile Home:** A detached portable residential Dwelling Unit with a floor area of at least 400 square feet, prefabricated on its own chassis and intended for long-term occupancy. The unit shall contain sleeping accommodations, a flush toilet, tub or shower, and eating and living quarters. It is designed to be transported on its own wheels or on a flatbed arriving at the site where it is to be occupied as a complete Dwelling without permanent foundations and shall be connected to existing utilities. A travel trailer is not to be considered a mobile home.

**Mobile Home Park:** A tract of land prepared and approved according to the procedures in this Zoning Ordinance to accommodate mobile homes on rented or leased Lots.

**Mobile Home Subdivision:** A legally platted residential subdivision accommodating mobile homes.

**Motel:** Any establishment in which individual cabins, courts, or similar substructures or units are let or rented to transients for periods of less than 30 days. The term "motel" shall include tourist cabins and motor courts. A motor court or motel shall not be considered or construed to be either a multiple Dwelling, a hotel, or a mobile home park.

**Motorized Vehicle Service Stations:** Buildings/Structures and premises used or designed to be used for the retail sale of fuels, lubricants, or grease, and other operating commodities for motorized vehicles, including the customary space and facilities for the installation of such commodities; and including space for temporary minor repair, or servicing such as polishing, washing, cleaning, greasing, but not including bumping, painting, or refinishing thereof.

**Motorized Vehicle Wrecking:** The dismantling or disassembling of used motorized vehicles or trailers, or the storage, sale, or dumping of dismantled, partially dismantled, obsolete, or wrecked motorized vehicles or their parts.

#### 6.1.14 'N' Definitions

Reserved

#### 6.1.15 'O' Definitions

**Off-Road Parking:** A facility providing motorized vehicle parking spaces with adequate drives and aisles for maneuvering so as to provide access for entrance and exit for the parking of motorized vehicles.

**Outdoor Wood Furnaces:** as defined by the Environmental Protection Agency (EPA) and including a boiler, wood-fired hydronic heater, any equipment, device, appliance or apparatus, or any part thereof, which is installed, affixed or situated outdoors for the primary purpose of combustion of wood to produce heat or energy used as a component of a heating system providing heat for any interior space or water source. The following associated definitions may also apply:

- a. **EPA Outdoor Wood Hydronic Heater (OWHH) Phase 1 Program Qualified Model:** An Outdoor Wood Furnace that has been EPA OWHH Phase 1 program qualified, meets all EPA OWHH Phase 1 emissions levels and has the proper qualifying label and hangtag.
- b. **Natural Wood:** Wood which has not been painted, varnished, or coated with a similar material, has not been chemically treated, has not been pressure treated with preservatives and does not contain resins or glues as in plywood or other composite wood products.

6.1.16 **‘P’ Definitions**

**Parking Space, Area, Lot:** An off-road open area, the Principal Use of which is for the parking of motorized vehicles, whether for compensation or not, or as an accommodation to clients, customers, visitors, or employees.

**Principal Building/Structure:** A Building/Structure in which the Principal Use of the Lot on which the Building/Structure is located is conducted.

6.1.17 **‘Q’ Definitions**

**Quarry:** Any pit, excavation, or mining operation for the purpose of searching for or removing from the premises any earth, rock, sand, gravel, clay, stone, slate, marble, or other non-metallic mineral in excess of 50 cubic yards in any calendar year, but shall not include an excavation preparatory to the construction of a Building/Structure or public road.

6.1.18 **‘R’ Definitions**

**Riding Academy:** Any establishment where horses are kept for riding, driving, or stabling for compensation or incidental to the operation of any club, association, ranch, or similar establishment.

**Road:** A public or private thoroughfare which affords the principal means of access to abutting property having a right-of-way not less than 66 feet in width.

**Roadside Stand:** A Structure temporarily operated for the purpose of selling produce primarily raised or produced on the premises where situated, and its Use shall not create a Commercial Zoning District, nor shall its Use be deemed a commercial activity.

6.1.19 **‘S’ Definitions**

**Sawmill:** motorized machine tools run by gasoline motors, diesel motors, electric motors or chainsaws and that is capable of being carried or moved about, and used by individuals, tradesman or professionals in producing limited volumes of boards cut from logs for personal use or profit.

**Site Plan Review:** A review by the Township Planning Commission and the Township Board of Trustees of certain Buildings/Structures that can be expected to have a significant impact on natural resources, traffic patterns, and on adjacent land usage.

**Story:** That portion of a Building/Structure included between the surface of any floor and the surface of the floor above it, or if there is no floor above it, then the space between the floor and the ceiling above it.

**Structure:** Anything constructed, erected or placed with a fixed location on the surface of the ground.

6.1.20 **‘T’ Definitions**

**Travel Trailer:** A vehicle designed as a travel unit for occupancy as a temporary or seasonal living unit, capable of being towed by a motorized vehicle.

6.1.21 **‘U’ Definitions**

Reserved

6.1.22 **‘V’ Definitions**

Reserved

6.1.23 **‘W’ Definitions**

**Wind Energy Conversion Systems (WECS):**

- a. Wind Energy Conversion System (WECS) shall mean any device such as a wind charger, windmill or wind turbine that converts wind energy to a form of usable energy.
  1. Agriculture WECS shall mean any WECS that is accessory to a permitted farm or agricultural operation, and is designed and built to serve the needs of the farm or agricultural operation.
  2. Private WECS shall mean any WECS that is accessory to a Principal Non-Farm, or Non-Agricultural Use located on the same Lot, and is designed and built to serve the needs of the Principal Use.
  3. Commercial WECS shall mean any WECS that is designed and built to provide electricity to an electric utility’s power grid.
- b. Manual and Automatic Controls shall mean that which protects a power grid and limits the speed of rotation of WECS’ blades at or below the designated limits of the conversion system.
- c. Authorized Factory Representative shall mean an individual who has received WECS technical training, including instruction in installation and maintenance, and is certified by the applicable WECS manufacturer.
- d. Professional Engineer shall mean any appropriately licensed engineer registered in the State of Michigan.
- e. Facility Abandonment shall mean a WECS which is out of production for a period of time of at least 12 months.

6.1.24 **‘X’ Definitions**

Reserved

6.1.25 **‘Y’ Definitions**

**Yard, Front:** An open, unoccupied land extending the full width of the Lot between the road right-of-way line and the nearest part of the Principal Building/Structure.

**Yard, Rear:** An open, unoccupied land extending the full width of the Lot between the rear line of the Lot and the rear line of the Principal Building/Structure.



**Yard, Side:** An open, unoccupied land on the same Lot with the Principal Building/Structure, between the side line of the Principal Building/Structure and the adjacent side line of the Lot and extending from the rear line of the front yard to front line of the rear yard, and if no front yard is required, the front boundary of the side yard shall be the front line of the Lot.

6.1.26 'Z' Definitions

**Zoning District:** A portion of the Township of Somerset within which certain uniform regulations and regulations apply under the provisions or this Zoning Ordinance.

Section 6.2 - ILLUSTRATIONS

- 6.2.1 Basement and Story Definition
- 6.2.2 Basic Structural Terms
- 6.2.3 Building Height Requirements

- 6.2.4 Corner interior and Condominium Unit Lots.
- 6.2.5 Lot terms
- 6.2.6 Yard Requirements

**Basement & Story Definition**

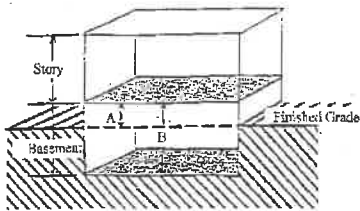

If the average of "A" is equal to or less than  $\frac{1}{2}$  of "B", this is a basement.

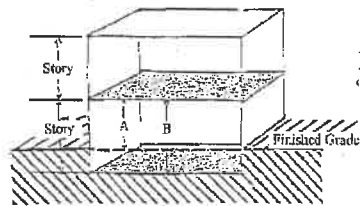

If the average of "A" is greater than  $\frac{1}{2}$  of "B", this is a story.

**Basic Structural Terms**

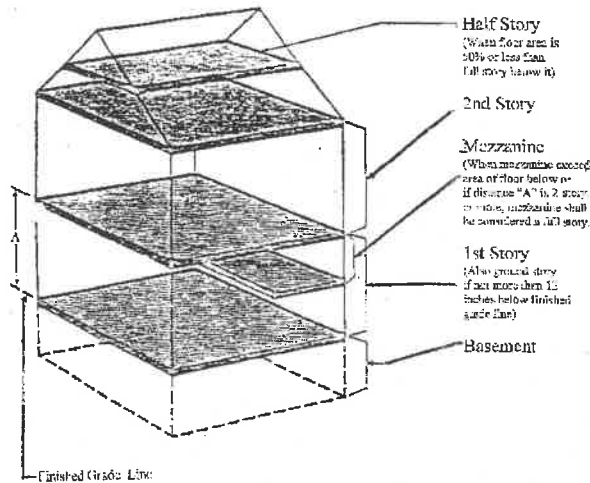

**Building Height Requirements**

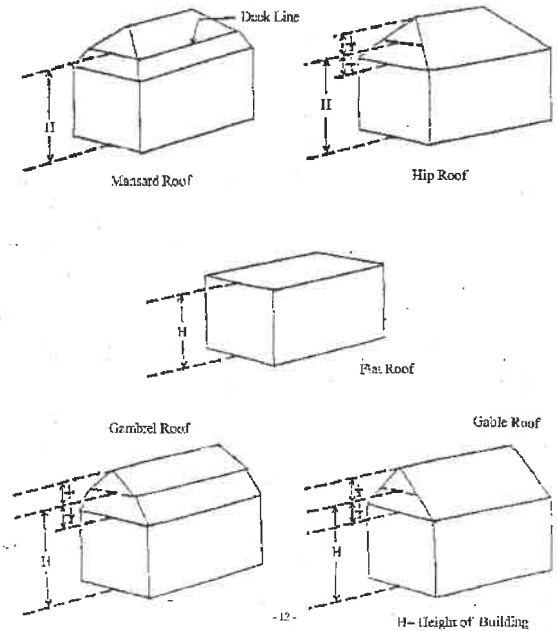

**Corner, Interior and Double Frontage Lots**

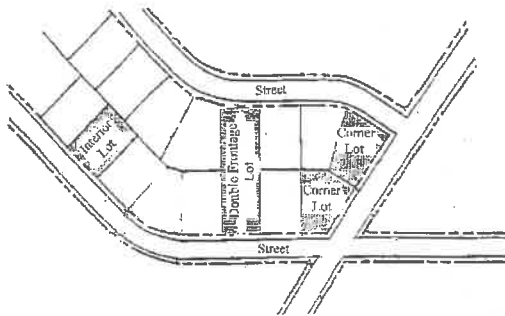

**Lot Terms**

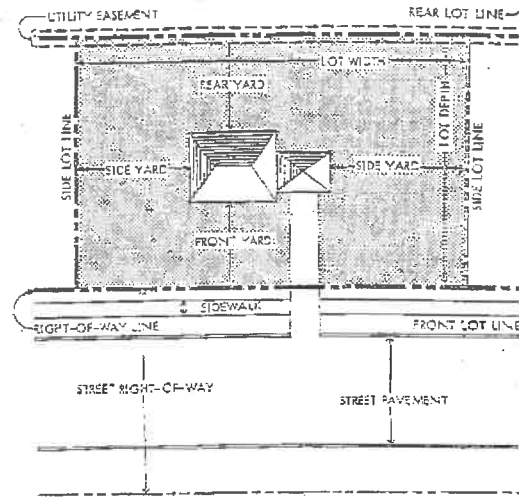

**Yard Requirements**

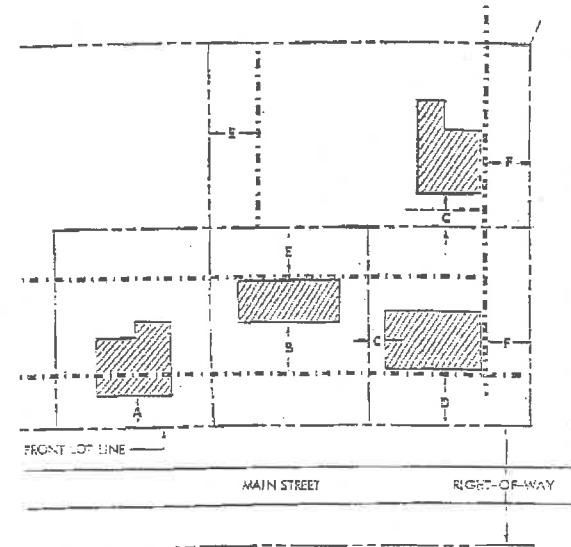

**LEGEND**

- A—Minimum front yard
- B—Front yard setback of minimum front yard required
- C—Minimum side yard required
- D—Minimum rear yard required Also building setback line
- E—Minimum rear yard required
- F—Minimum yard required for side access when front lot is

**Section 6.3 - UNDEFINED TERMS**

Any term not defined herein shall have the meaning of common or standard use.

*This page is intentionally blank.*

## Article VII LEGAL STATUS

### SECTION 7.1 – CONFLICT WITH OTHER LAWS

Conflicting laws of a more restrictive nature are not affected or repealed by this Zoning Ordinance. The provisions of this Zoning Ordinance shall be considered as minimum. Conflicting laws of a less restrictive nature, or those conflicting in other ways than degrees of restrictiveness, are hereby repealed.

This Zoning Ordinance is not intended to abrogate or annul any easement, covenant, or other private agreement provided that where any provision of this Zoning Ordinance is more restrictive or imposes a higher standard or requirement than such easement, covenant, or other private agreement, the provision of this Zoning Ordinance shall govern.

### SECTION 7.2 – VALIDITY AND SEVERABILITY CLAUSE

If any court of competent jurisdiction shall declare any part of this Zoning Ordinance to be invalid, such ruling shall not affect any other provisions of this Zoning Ordinance not included in said ruling. If any court of competent jurisdiction shall declare invalid the application of any provision of this Zoning Ordinance to a particular land, parcel, Lot, Zoning District, Use or Building/ Structure, such ruling shall not affect the application of said provision to any other land, parcel, Lot, Zoning District, Use or Building/ Structure not specifically included in said ruling.

### SECTION 7.3 – PERIOD OF EFFECTIVENESS:

This Zoning Ordinance shall become effective 9/11/2020.

### SECTION 7.4 – REPEAL OF ORDINANCE:

The Township of Somerset Zoning Ordinance, Hillsdale County, Michigan adopted on January 18, 1973, and all amendments thereto, are hereby repealed effective coincident with the effective date of this Zoning Ordinance.

### SECTION 7.5 – EFFECTIVE DATE:

This Zoning Ordinance was adopted by the Township Board of Trustees of the Township of Somerset, Hillsdale County, Michigan at a meeting held on 8/20/2020 and a notice ordered published in the HILLSDALE DAILY NEWS, a newspaper having general circulation in said Township of Somerset.

Township Supervisor



Township Clerk

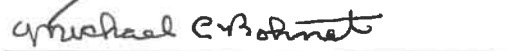

Effective 9/11/2020